

MP197HB; First Licensed Transportation Package with Canistered High Burnup Fuel after Dry Storage – 15580

Jayant Bondre
AREVA TN

ABSTRACT

AREVA TN has recently received the NRC 10 CFR Part 71 transportation license CoC 9302 Revision 7 for the MP197HB transportation package that allows transportation of canistered high burnup fuel assemblies. The Nuclear Horizontal Modular Storage (NUHOMS®) system canisters containing high burnup PWR and BWR fuel assemblies are now licensed for transportation as a payload in MP197HB after these canisters were in dry storage at the utility ISFSIs. Enhancements have been made to the MP197HB transportation package to improve thermal performance and also provide superior shielding capabilities. Design features of existing AREVA TN transportation packages such as radial fins, thermal shield, neutron resin and optimized gamma and neutron shielding were used to accommodate transportation of high burnup fuel assemblies with heat loads up to 32kW. The transportation package is designed for exclusive use by rail, truck or marine transport.

State-of-the-art analyses methodologies were used to demonstrate compliance with regulatory requirements of 10 CFR 71.55 for the high burnup fuel after dry storage at any ISFSI. Some of the issues addressed in the license application related to the transportation of high burnup fuel included potential degradation of fuel cladding, uncertainty associated with high burnup fuel cladding material properties, and larger radiation and thermal sources due to higher burnups. Bounding conservative assumptions were made where limited test data was available. AREVA TN's licensing approach did not rely on the cladding integrity of high burnup fuel cladding. Instead, the criticality, thermal and shielding analyses were carried out assuming high burnup fuel reconfiguration.

With the approval of this transportation package for PWR and BWR canistered high burnup fuel from dry storage at ISFSIs, the utilities can now transport these canisters which are in dry storage at their sites. This is also a major step forward for the canistered fuel that is currently in dry storage at the shutdown plants because they can use this AREVA TN MP197HB transportation package to ship that fuel to any interim storage facility (ISF) or to a repository when they become available.

INTRODUCTION

As burnups of the discharged used fuel assemblies (UFAs) from nuclear reactors are increasing, decay heats from these UFAs are also increasing. The dry storage systems currently being procured by the utilities have high burnup, high heat load UFAs. The heat loads are expected to be high at the time of transportation of these UFAs. If the transportation package is not licensed for high heat loads, then there will be significantly longer cooling times required before these UFAs can be transported.

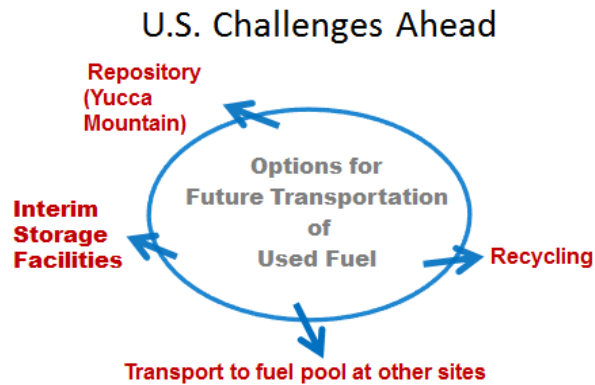

Figure 1. U.S. Challenges Ahead

The AREVA TN's MP197HB Transportation Package is licensed for transportation of high burnup used fuel assemblies (UFAs) under U.S. Nuclear Regulatory Commission (NRC) requirements of 10CFR Part 71, Certificate of Compliance (CoC) No. 9302. The MP197HB is the first and only licensed transport package that conforms to the rigorous NRC requirements for high burnup canistered fuel. In addition, the MP197HB transportation package is licensed to transport the highest heat load capacity canisters in the industry as a payload, with an allowable heat load of up to 32 kW.

The MP197HB is also the first truly universal transport package to enter the used UFA transportation market. It is unique in that its cavity can be reconfigured for different canister lengths and widths. It is now licensed to transport nine different dry shielded canister types, including AREVA TN's, NUHOMS® family of high-performance canisters for UFAs and the AREVA TN Nuclear Horizontal Waste Storage (NUHOWS) Radwaste Canister (RWC). It can be used to safely transport used fuel from one site to another – as is needed in certain cases of a plant decommissioning – to an interim storage facility, recycling or to a final geological repository as shown in Figures 1 and 2.

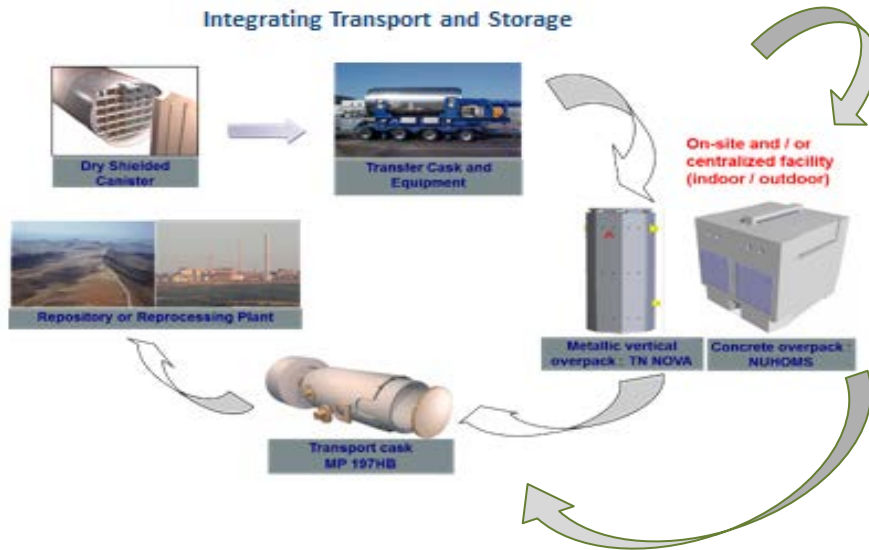

Figure 2. Integrating Transport and Storage

The NUHOMS® MP197HB transportation package has been approved for rail, truck and marine transport. The NUHOMS® MP197HB transportation is currently being fabricated.

MP197HB TRANSPORTATION PACKAGE DESCRIPTION

The MP197HB packaging is fabricated primarily of nickel-alloy steel (NAS). Other materials include the cast lead shielding between the containment boundary inner shell and the structural shell, the O-ring seals, the resin neutron shield, and the carbon steel closure bolts. Socket headed cap screws (bolts) are used to secure the lid to the package body and the RAM access port closure plate to the bottom of the package where RAM access port is to pull the canister from storage overpack into the MP197HB cavity or push the canister out from the MP197HB cavity. The body of the packaging consists of a NAS inner shell, 31.75mm (1.25 inch) thick with a 1790.70mm (70.5 inch) inside diameter, and a NAS outer shell, 69.85mm (2.75 inch) thick with a 2146.30mm (84.5 inch) outside diameter, which sandwich the 76.20mm (3 inch) thick cast lead shielding material.

The packaging is 6888.86mm (271.215 inches) long with a diameter of 3200.40mm (126 inches), when both impact limiters are installed. The impact limiters are made of redwood and balsa wood encased in a stainless steel cover. The packaging diameter, including the radial neutron shield, is 2482.85mm (97.75 inches) without the fins or 2647.95mm (104.25 inches) with the fins. The fins are an optional feature for heat loads less than or equal to 26 kW. The packaging cavity is 5060.95mm (199.25 inches) long and 1790.70mm (70.5 inches) in diameter without the internal sleeve (discussed below) or 1727.20mm (68 inches) in diameter with the sleeve.

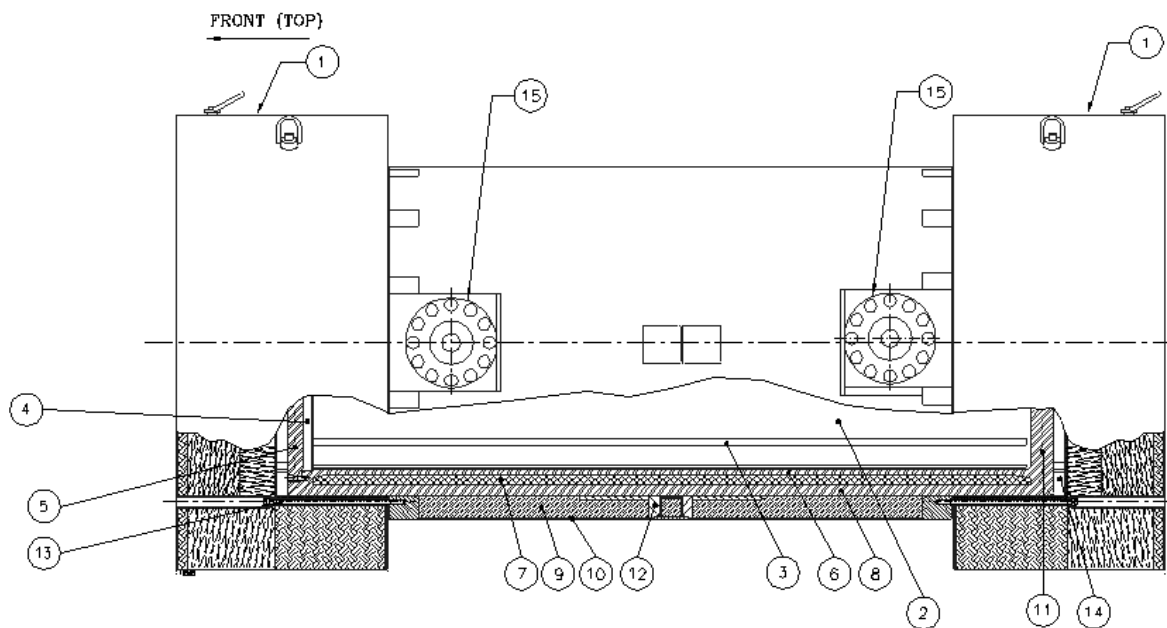

- | | | | |
|---|------------------------------------|----|---------------------------------------|
| 1 | Impact Limiter | 9 | Transport Cask Neutron (Resin) Shield |
| 2 | Transport Cask Cavity | 10 | Transport Cask Shield Shell |
| 3 | Transport Cask Slide Rail | 11 | Transport Cask Bottom |
| 4 | Hold Down Ring (if required) | 12 | Transport Cask Bearing Block |
| 5 | Transport Cask Lid | 13 | Impact Limiter Attachment Bolt |
| 6 | Transport Cask Inner Shell | 14 | Thermal Shield |
| 7 | Transport Cask Gamma (Lead) Shield | 15 | Trunnion |
| 8 | Transport Cask Outer Shell | | |

Figure 3. General Arrangement of the NUHOMS® - MP197HB Packaging

The package containment boundary consists of the inner shell, a 165.10mm (6.5 inch) thick bottom plate with a 733.55mm (28.88 inch) diameter, a 63.50mm (2.5 inch) thick RAM access closure plate with seal and bolts, a package body flange, a 114.30mm (4.5 inch) thick lid with seal and bolts, vent and drain ports with closures bolts and seals, and all containment welds as shown in Figure 3. No credit is taken for the canister as a containment boundary.

An inert atmosphere (helium) is maintained in the package cavity. The neutron and gamma shielding geometry is optimized for high burnup fuel. Shielding is provided by approximately 101.60mm (4 inches) of steel, 76.20mm (3 inches) of lead and 158.75mm (6.25 inches) of neutron shielding assembly.

The MP197HB uses an internal aluminum sleeve for smaller diameter dry storage canisters and RWCs. The inner sleeve is designed with slots to accommodate the existing rails inside the packaging and to provide rails inside the sleeve on which the smaller diameter canisters or

secondary containers slide during horizontal loading or unloading of the package. The gross weight of the loaded package is 138 tonnes including a maximum payload of 50.8 tonnes. Four removable trunnions, attached to the package body, are provided for lifting and handling operations, including rotation of the packaging between the horizontal and vertical orientations. An aluminum thermal shield is added to each impact limiter to reduce the impact limiter wood temperature. A personnel barrier is mounted to the transportation frame to prevent access to the body of the package.

MP197HB PACKAGING PAYLOAD DESCRIPTION

There are nine canister designs and a radioactive waste canister authorized for transport in the NUHOMS®-MP197HB packaging. The packaging cavity is designed to accommodate the larger 1772.92mm (69.8 inch) diameter canisters (32PTH, 32PTH1, 37PTH, and 69BTH canister). To accommodate the smaller 1709.42mm (67.3 inch) diameter canisters (24PT4, 24PTH, 32PT, 61BT, and 61BTH canister) or RWC, an aluminum inner sleeve is provided. To accommodate the varying lengths of the canisters and RWCs, stainless steel or aluminum spacers are provided to limit axial movement of the payload. In order to address “secondary impact” during transportation accidental drop conditions, spacers are installed in the MP197HB packaging cavity or canister cavity, to limit the axial gaps between the components as determined by the analysis requirements. The canister allows the transfer of spent fuel assemblies, into or out of a storage module, a dry transfer facility, or a pool as a unit. The canister also provides additional axial biological shielding during handling and transport.

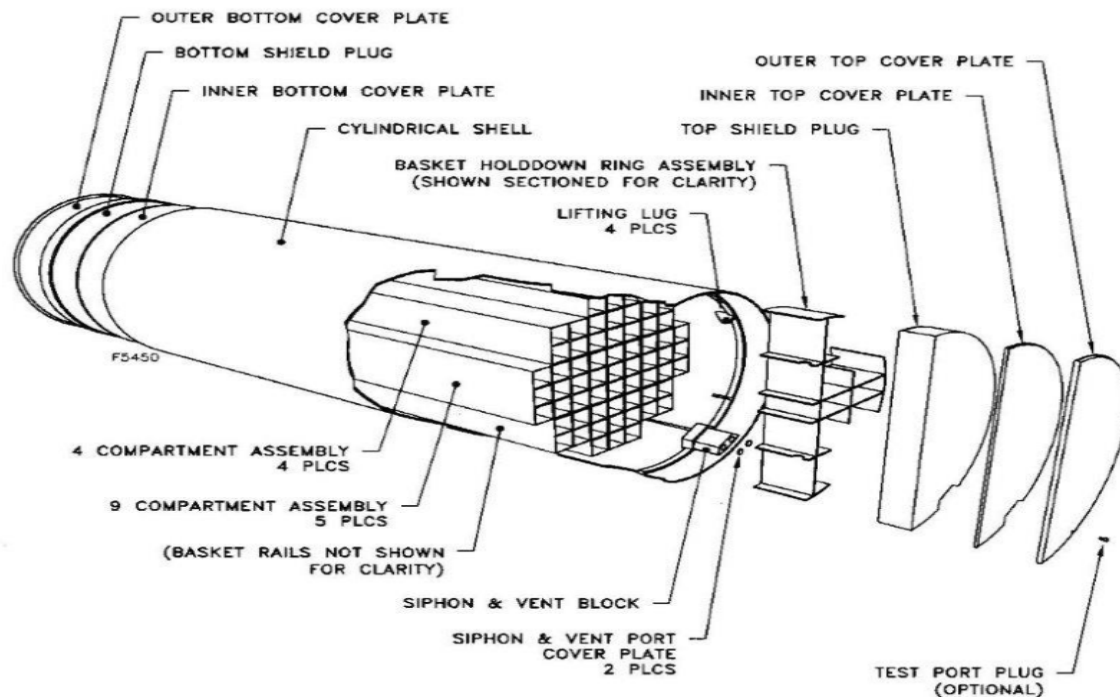

Figure 4. 61BTH Cross Section

The canister basket assembly provides criticality control and contains a storage position for each fuel assembly. The canister basket structure consists of a welded assembly of stainless steel tubes (fuel compartments) separated by poison plates and surrounded by larger stainless steel boxes and support rails as shown in Figure 4. The canister basket poison plates are constructed from Boral®, borated aluminum or aluminum/B4C metal matrix composite (MMC) and provide a heat conduction path from the fuel assemblies to the canister wall, as well as the necessary criticality control.

DESIGN APPROACHES FOR HIGH BURNUP FUEL

Prevalent definition of high burnup fuel is fuel that is irradiated to a burnup level greater than 45,000 MWD/MTU. The MP197HB transport package design addresses issues associated with high burnup fuel that include the following:

- Potential for degradation of fuel cladding. The potential effect of Ductile – Brittle Transition Temperature (DBTT) that typically occurs during dry storage as the fuel cools down. The values are dependent on clad material, irradiation and thermal history. Therefore, the minimum cladding temperatures above DBTT, including the considerations for uncertainty in the DBTT for transport, needs to be maintained to avoid potential for degradation of fuel cladding.
- Uncertainty associated with high burnup fuel cladding material properties resulting in potential issues with meeting the requirements of 10 CFR 71.55(b), 10 CFR 71.55(d) and 10 CFR 71.55(e). The high burnup fuel cladding properties require justification for use in safety analyses for transportation following extended dry storage.
- Larger radiation source terms that require Benchmarking of computer codes to perform calculations to determine decay heat, neutron and gamma source terms.

These issues for high burnup fuel are addressed in the MP197HB transport package design, analysis and licensing approaches by applying conservative methodologies like consideration of intact high burnup fuel as damaged to demonstrate that the package meets the regulatory criteria. The licensing approach used to demonstrate compliance with the requirements of 10CFR 71.55 (d) does not rely upon cladding integrity of the fuels. The criticality, thermal, and shielding analyses are performed assuming fuel reconfiguration. The licensing approach used to demonstrate compliance with 10CFR 71.55 (e) rely on moderator exclusion.

CONCLUSIONS

The MP197HB is the first and only licensed transport package that conforms to the rigorous NRC requirements for high burn-up canistered fuel with the highest heat load in the industry as a payload, with an allowable heat load of up to 32 kW.

The MP197HB is also the first truly universal transport package to enter the used nuclear fuel (UNF) transportation market. It is unique in that its cavity can be reconfigured for different canister lengths and widths. It is now licensed to transport nine different dry shielded canister types, including AREVA TN's, NUHOMS® family of high-performance canisters for UFAs and the AREVA TN NUHOWS Radwaste Canister. It can be used to safely transport used fuel

from one site to another – as is needed in certain cases of a plant decommissioning – to an interim storage facility or to a final geological repository.