

Small Column Ion Exchange Design and Safety Strategy - 11325

Thomas Huff*, Maria Rios-Armstrong*, Richard Edwards*, David Herman**

* Savannah River Remediation LLC, Aiken, SC 29808

** Savannah River National Laboratory, Aiken, SC 29808

ABSTRACT

Small Column Ion Exchange (SCIX) is a transformational technology originally developed by the Department of Energy (DOE) Environmental Management (EM-30) [1] office and is now being deployed at the Savannah River Site (SRS) to significantly increase overall salt processing capacity and accelerate the Liquid Waste System life-cycle.

The process combines strontium and actinide removal using Monosodium Titanate (MST) [2], Rotary Microfiltration [3], and cesium removal using Crystalline Silicotitanate (CST, specifically UOP IONSIV® IE-911 ion exchanger [4]) to create a low level waste stream to be disposed in grout and a high level waste stream to be vitrified. The process also includes preparation of the streams for disposal, e.g., grinding of the loaded CST material. These waste processing components are technically mature and flowsheet integration studies are being performed including glass formulations studies, application specific thermal modeling, and mixing studies. The deployment program includes design and fabrication of the Rotary Microfilter (RMF) assembly, ion-exchange columns (IXCs), and grinder module, utilizing an integrated system safety design approach.

The design concept is to install the process inside an existing waste tank, Tank 41H. The process consists of a feed pump with a set of four RMFs, two IXCs, a media grinder, three Submersible Mixer Pumps (SMPs), and all supporting infrastructure including media receipt and preparation facilities. The design addresses MST mixing to achieve the required strontium and actinide removal and to prevent future retrieval problems. CST achieves very high cesium loadings (up to 1,100 curies per gallon (Ci / gal) bed volume). The design addresses the hazards associated with this material including heat management (in column and in-tank), as detailed in the thermal modeling [5]. The CST must be size reduced for compatibility with downstream processes. The design addresses material transport into and out of the grinder and includes provisions for equipment maintenance including remote handling.

The design includes a robust set of nuclear safety controls compliant with DOE Standard (STD)-1189, Integration of Safety into the Design Process [6]. The controls cover explosions, spills, boiling, aerosolization, and criticality. Natural Phenomena Hazards (NPH) including seismic event, tornado / high wind, and wildland fire are considered. In addition, the SCIX process equipment was evaluated for impact to existing facility safety equipment including the waste tank itself.

SCIX is an innovative program which leverages DOE's technology development capabilities to provide a basis for a successful field deployment.

INTRODUCTION

Background

The Salt Waste Processing Facility (SWPF) is the planned facility that will remove the majority of the cesium from soluble alkaline waste solutions by the Caustic Side Solvent Extraction (CSSX) process and strontium and actinides by treatment with MST and filtration at SRS. Extensive work was done to select the technology for SWPF [7]. One of the final four alternatives was a large column design using CST resin. This technology was not chosen for this application mainly due to heat concerns in a large column; however, CST ion exchange remained the backup technology.

Ion exchange process technology to treat spent nuclear alkaline waste has been studied and evaluated for many years. Ion exchange process technology evaluations to treat nuclear waste were performed at Sandia National Laboratory and Oak Ridge National Laboratory (ORNL) in the 1990s using CST as an ion exchange resin [8, 9, 10]. After down selection for SWPF was completed, the application of ion exchange technology continued to be matured within the DOE-EM (now EM-31; includes any of its predecessors) technology development program. As a result of the ongoing development, a shift from a large column to a small column concept was identified. This concept alleviates the heat buildup issue found in the large columns and supports a preferred method of modular deployment at tank top / tank side for an existing waste tank thus obviating the need to build more shielded facilities. The small column size was successfully tested by Savannah River National Laboratory (SRNL) and ORNL to verify the cooling capacity [11], among other concerns, and a pre-conceptual design feasibility study [1] was successfully completed to verify deployment in a waste tank was indeed possible.

After the Savannah River Remediation (SRR – SRS Liquid Waste contractor) contract was awarded in 2009, SRR proposed to implement the SCIX Program as a system lifecycle improvement option in a meeting with DOE EM in October 2009. DOE EM accepted the SRR proposal.

Lifecycle Benefit

Revision 15 of the SRS Liquid Waste System Plan [12] forecasted the production of approximately 250 “salt-only” canisters during the period from May 2023 (when all sludge has been depleted) to December 2030. An opportunity exists to reduce or eliminate this “salt-only” campaign by augmenting the total salt processing capacity of the liquid waste system.

The SCIX Program has the capacity to produce approximately 2.5 million gallons per year (Mgal / yr) of Decontaminated Salt Solution (DSS). The SCIX Program could begin operating as soon as October 2013 and, by increasing overall salt waste processing, would enable completion of salt processing in December 2024, a full 6 years sooner than projected by the system plan. This savings equates to approximately \$3 billion in life cycle costs. Revision 16 of the SRS Liquid Waste System Plan [13] incorporates the SCIX Program into the SRS Liquid Waste (LW) flowsheet closing the gap between salt and sludge processing. No “salt-only” canisters are produced in Revision 16 of the System Plan.

PROCESS DESCRIPTION

Figure 1 shows a simplified process diagram for SCIX. All of the process equipment will be installed in Tank 41H in H-Tank Farm at SRS.

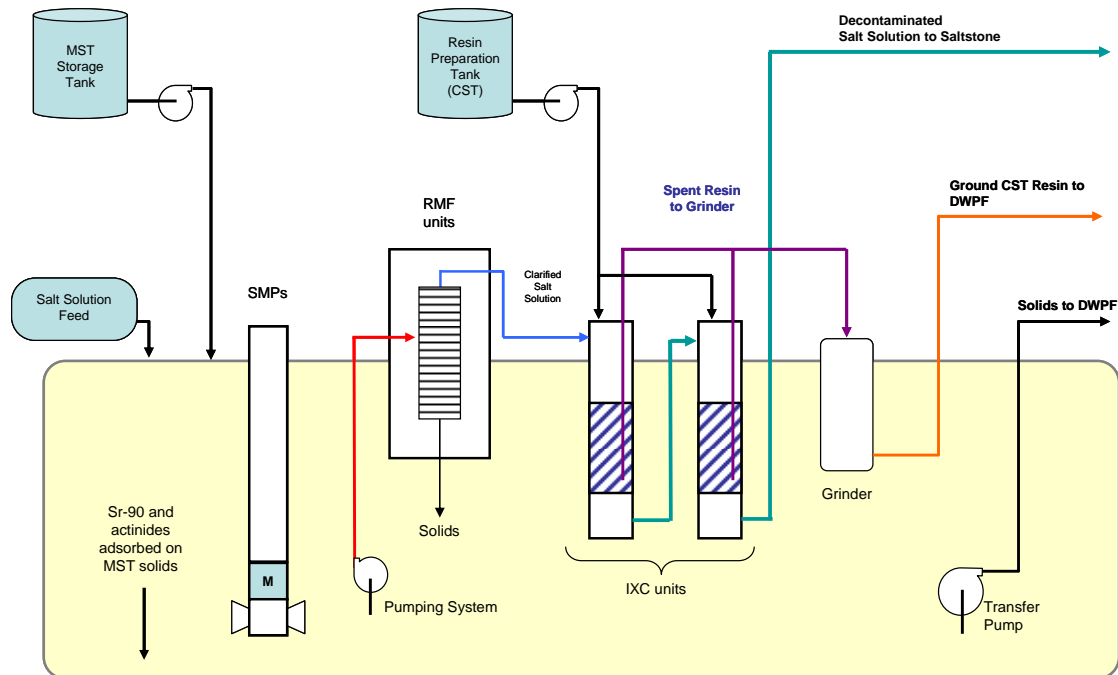

Figure 1. Simplified process diagram for SCIX.

The basic process operation includes the steps listed below. Estimated nominal durations are included within brackets [14]. All of the values contained herein are nominal values and are provided for information. Actual values may vary on a batch per batch basis.

1. Transfer salt solution feed into Tank 41H until the level reaches 350" (from tank bottom). Transfer of salt solution into Tank 41H is assumed to be jetted at 75 gallons per minute (gpm). [10 days]
2. Add 1,400 kilograms (kg) MST to Tank 41H (reaching a concentration of 0.4 grams (g) MST / Liter (L) waste). [3 days]
3. Mix the tank contents with 3 SMPs. [3 days]
4. Sample the tank and wait for initial results. [7 days]
5. Start the RMF feed pump. Operate the process at 10 gpm throughput.
6. Process 200,000 gallons of salt solution. [14 days]
7. The lead column, containing approximately 1,620 kg CST, is sluiced to the grinder and size reduced to a mean particle size of 5-20 micron with a maximum of 38 micron. The ground CST is sent to Tank 40H, the Defense Waste Processing Facility (DWPF) feed tank, with 2,500 gallons of Inhibited Water (IW). CST is loaded up to 1,100 Ci / gal (285 Ci / kg). Fresh CST is pretreated, transferred to the empty column, and backpulsed to set the bed; lead and lag columns are swapped; and the SMPs are run during downtime. [2 days]

8. Repeat steps 5-7 until the tank level reaches 100”.
9. Stop process; start SMPs; and transfer the MST / sludge solids to Tank 42H or Tank 51H, the sludge batch preparation tanks, depending on sludge batch cycle, until the level in Tank 41H reaches 30”. Transfer will contain 1,400 kg MST. This transfer is assumed to be pumped at 120 gpm. Stop the transfer pump and the SMPs at completion of the transfer. [1.5 days]

The batch cycle times are summarized in Table I. The design basis throughput is summarized in Table II.

Table I. Batch Cycle Time Summary [14]

Process Step	Duration
Fill Batch	10 days
MST Addition	3 days
MST Mix	3 days
Sample and Hold	7 days
Process Batch	61 days
Column Changeouts	10 days
Pump Out Solids	1 day
Total	96 days

Table II. SCIX Design Basis Throughput [14]

Process Step	Per Batch	Per Year
Transfer Salt Feed into Tank 41H	1,123,200 gal	4.3 Mgal / yr
Process Salt Feed to Saltstone	877,500 gal	3.3 Mgal / yr
Pump Heel to Sludge Batch	245,700 gal	0.9 Mgal / yr
CST to Tank 40H	8,150 kg	31,065 kg / yr
MST to Tank 42H / 51H	1,400 kg	5,336 kg / yr

Utility

The SCIX system is expected to have 75% utility. The utility adjusted DSS production rate is 2.5 Mgal / year. This rate supports the lifecycle benefit of eliminating salt-only canisters at DWPF.

DESIGN

Four modules have been identified for the SCIX Program and are described in the paragraphs that follow. Figure 1 shows a simplified process diagram for the SCIX Program and the components described below.

Rotary Micro-filters

The RMF Component will be installed in a riser of Tank 41H and consists of a pumping system, RMF units, and piping to transfer the filter effluent or Clarified Salt Solution (CSS) to the IXC. The transfer lines from the RMF units to the IXCs will be above ground and utilize secondary containment and shielding as appropriate. The RMF pumping system will utilize one submersible centrifugal pump feeding four RMF units connected in parallel and installed in a riser of the waste tank. The submersible RMF feed pump provides the motive force for transferring the salt solution to the RMF units, forcing the salt solution through the RMF housing, transferring the CSS from the RMFs to the IXCs, pumping the CSS through the IXC resin beds, and pumping the IXC effluent (DSS) to Tank 50H, the Saltstone production Facility (SPF) feed tank.

Each RMF unit contains a series of flat, round, 0.5 micron filter element disks set on a hollow rotating shaft inside a stationary cylindrical pressure vessel. Salt solution enters the element chamber under pressure, is distributed across the element surface, and is forced through the element. The filtrate (CSS) is collected in the hollow shaft and is discharged to the IXCs. Solids and excess unfiltered solution are continuously returned to the waste tank. Stationary disks oppose the rotating element disks and provide a means for prohibiting fluid rotation. The rotation of the elements near the stationary disks provides a large amount of turbulence at the element surface. Centrifugal force acts to carry away the solids, minimizing the deposition and obviating the need for a back pulse system. A connection for adding nitric acid or other chemicals to clean / dissolve debris from a plugged element is also included.

The Tank 41H riser that contains the RMF component has a stainless steel liner / shroud assembly inserted in the riser to protect the waste tank components from the effects of contact with nitric acid. The in-tank shroud has louvers cut into it that direct any free draining nitric acid away from tank components and vent the shroud to the tank vapor space. The RMFs and associated piping and valves are located inside the RMF unit. The unit components are constructed of stainless steel and chemical resistant materials and are well shielded for radiation reduction. The unit is designed to mount inside a process tank riser and be free draining into the process tank via the louvered shroud.

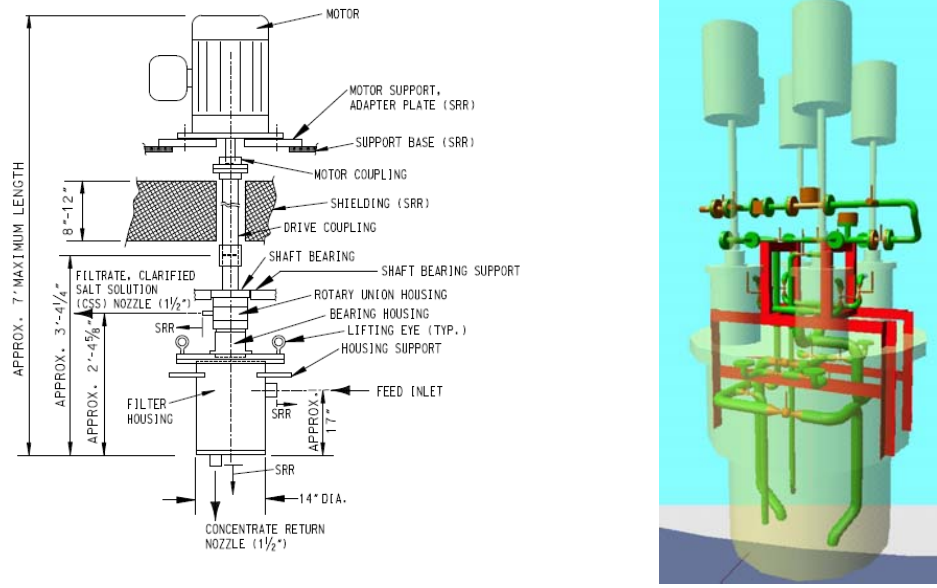

Figure 2. Conceptual design of the RMF Component.

Ion Exchange Column

The IXC Component will be installed in risers of Tank 41H and includes the ion exchange media, the ion exchange column, piping to transfer the DSS between the two IXCs, and piping to transfer the DSS from the IXC to Tank 50H. Piping is also included to transfer the spent resin out of the columns to the Spent Resin Disposal (SRD) Component. CSS, the effluent from the RMF Component, will be pumped through two IXCs operating in series to remove Cesium (Cs-137) from the waste stream. The baseline ion exchange media to be used in the IXCs is CST resin, specifically UOP IONSIV® IE-911 ion exchanger. CST exchange media is an inorganic non-combustible, non-flammable, once used material that cannot be regenerated. Once fully loaded with Cs-137, the spent CST resin must be sluiced from the IXC column and transferred to the SRD to reduce the particle size. The IXC will be equipped with two sluice lines to allow sluicing half a batch volume at a time or the whole batch depending on the disposal capacity. The ground CST resin is then transferred to Tank 40H for eventual vitrification. The spent CST must be ground to facilitate transfer to a sludge batch tank and to enable re-suspension of the ground CST resin for transfer to DWPF. Prior to sluicing spent CST resin from the column, the resin is conditioned by adding caustic and IW. Once conditioned, the CST resin and any remaining liquid are sluiced from the column to the SRD using Plant Air (PA) or IW. The final IXC effluent, or DSS, is pumped to Tank 50H for eventual processing into grout at SPF.

Cooling for both columns will be provided by both internal and external cooling loops associated with a stand-alone, closed loop cooling system. The IXC columns will be operated in series in a lead-lag configuration. Piping arrangement will permit either column to operate as the lead column. Only the lead column is regenerated at the end of a cycle and the lag column is switched into the lead position for the subsequent cycle.

Spent Resin Disposal

Spent CST resin will need to be size-reduced in the SRD for eventual disposal at DWPF. The SRD Component includes the grinder, piping, and eductor to transfer the spent CST resin. Cooling for the SRD will be provided by both internal and external cooling loops associated with the same stand-alone, closed loop cooling system as the IXC's. The above ground piping used to transfer the spent CST resin to Tank 40H will be jacketed in order to provide secondary containment and have appropriate shielding installed.

Common Plant Equipment

The Common Plant Equipment (CPE) Component includes the sub-components Chemical Feed, Resin Preparation, and Balance of Plant. These three sub-elements are described below.

The Chemical Feed supplies water, air, nitric acid, and caustic to SCIX equipment and processes. Inhibited / Process Water is needed for the following: flushing pumps, filters, and piping; sluicing the spent CST resin from the IXC to the SRD; fluidizing a new column bed to ensure equal distribution within the column; and washing new resin in the Resin Preparation Tank to remove fines generated during handling. Multiple water washes are needed for each CST resin charging cycle. Instrument / Plant Air is needed to remove residual waste products from the RMF, IXC, and SRD prior to maintenance, sluice spent CST resin from the IXC to the SRD, and to operate pneumatic valving. Nitric acid is supplied to the RMF to dissolve element pluggage. Caustic is added to the CST resin in the IXC after the transfer of fresh media into the column and prior to sluicing spent media from the column. Caustic addition sufficiently increases the pH to prevent aluminum precipitation from residual supernate in the IXC. This Chemical Feed also includes the storage of MST and the equipment needed to add and disperse MST to the process tank for strontium and actinide removal.

Resin Preparation is a skid containing a 750 gallon stainless steel tank with required process connections to transfer new CST resin to the IXC's. An air connection and pressure relief valve are provided for pressurizing the tank for charging the prepared CST resin to the IXC's. Preparation of the resin is conducted on or directly adjacent to the process tank top. CST resin preparation includes back flushing with Process Water (PW) to expand the resin, flushing the CST resin with IW to remove fines, and adjusting the pH using sodium hydroxide. The tank is vented during these activities. An in-line filter in the process drain captures the fines rinsed from the resin. The skid will be transported by forklift to the process tank risers, where the CST resin will be sluiced into the IXC's using air.

In addition to the Chemical Feed and Resin Preparation, the Balance of Plant will provide new equipment or use pre-existing equipment to support the RMF, IXC, and SRD components. This equipment includes transfer pumps, transfer lines, sluicing system with lines, air / water lines, SMPs, waste tank ventilation, cooling system, and electrical support.

SAFETY BASIS

An evaluation of the SCIX impact on the Concentration, Storage, and Transfer Facilities (CSTF) Safety Basis is provided in the Preliminary Consolidated Hazards Analysis (PCHA) [15]. The PCHA was performed based on the criteria in 10 Code of Federal Regulations (CFR) 830, DOE-

STD-3009-94, and DOE-STD-1189. Only those events that were unique or new due to the SCIX Program, and that could change an existing bounding Documented Safety Analysis (DSA) event consequence or change a control set, were evaluated in the PCHA.

The PCHA events postulated for the SCIX Program are summarized for each event type in Table III. No events exceeded the offsite evaluation guidelines (EGs) and criteria in Appendix A of DOE-STD-1189. That is, no hazardous events were identified that challenged the offsite evaluation guideline. However, several events exceeded the onsite worker evaluation guideline and criteria in Appendix A of DOE-STD-1189.

Table III. PCHA Events for the SCIX Program

Hazard Event Type	Description of Bounding Event	Exceeds Onsite EG
Fire	N / A: Boiling of waste is not credible in the SCIX process due to the SCIX process location inside the riser, materials of construction / configuration (sealed from fire sources), and physics of heat transfer.	N / A
Explosion	Deflagration / Detonation of the IXC due to flammable vapor accumulation results in the release of waste.	Yes
Loss of Confinement	High pressure air impinges on the liquid surface aerosolizing waste in the SRD resulting in an airborne release.	Yes
Exposure	IXC Pressure boundary breach into cooling water system results in direct radiological exposure.	No
Criticality	N / A: Criticality in the SCIX process is considered incredible preliminarily based on Reference 16.	N / A
External Events	N / A: External Events were considered as part of the Loss of Confinement Events.	N / A
NPH	Seismic event results in aerosolization of the SRD and the Waste Tank.	Yes

Unmitigated chemical consequences to the onsite and public were calculated consistent with the guidance provided by Appendix B of DOE-STD-1189-2008. None of the analyzed events exceed the Protective Action Criteria (PAC)-2 offsite or PAC-3 onsite limits.

Based on the guidelines and criteria set forth within Appendices A and B of DOE-STD-1189, there are Design Basis Accidents (DBA) for the SCIX Program. Some events unique to SCIX are already addressed in the CSTF DSA (i.e., transfer lines, SMPs, waste tank, transfer pumps).

Events requiring the use of safety Systems, Structures, and Components (SSC) or administrative controls to reduce the frequency or consequences of the events have been identified. These controls are identified for the bounding accidents postulated in the Hazards Analysis (HA), and the applicability of the controls for a given evolution. Many of the features / controls protecting workers contribute to the Defense-In-Depth (DID) of the facility. Events requiring safety controls due to Facility Worker (FW) consequences that did not get carried forward into the DBAs have also been identified.

ACRONYMS

CFR	Code of Federal Regulation
Ci / gal	Curies per Gallon
Ci / kg	Curies per Kilogram
CPE	Common Plant Equipment
Cs-137	Cesium-137
CSS	Clarified Salt Solution
CSSX	Caustic Side Solvent Extraction
CST	Crystalline Silicotitanate
CSTF	Concentrate, Storage, and Transfer Facility
DBA	Design Basis Accident
DID	Defense in Depth
DOE	Department of Energy
DSA	Documented Safety Analysis
DSS	Decontaminated Salt Solution
DWPF	Defense Waste Processing Facility
EG	Evaluation Guidelines
EM	Environmental Management
FW	Facility Worker
g / L	Grams per Liter
gpm	Gallons per Minute
HA	Hazards Analysis
IW	Inhibited Water
IXC	Ion Exchange Column
kg	Kilograms
LW	Liquid Waste
Mgal / yr	Million Gallons per Year
MST	Monosodium Titanate
NPH	Natural Phenomena Hazard
ORNL	Oak Ridge National Laboratory
PA	Plant Air
PAC	Protective Action Criteria
PCHA	Preliminary Consolidated Hazards Analysis
PW	Process Water
RMF	Rotary Microfilter
SCIX	Small Column Ion Exchange
SMP	Submersible Mixer Pump

SPF	Saltstone Processing Facility
SRD	Spent Resin Disposal
SRNL	Savannah River National Laboratory
SRR	Savannah River Remediation
SRS	Savannah River Site
SSC	Systems, Structures, and Components
STD	Standard
SWPF	Salt Waste Processing Facility

REFERENCES

- 1 Walker, Jr. J. F., Taylor, P. A., et. al., ORNL/TM-2003/287, *Small-Column Ion-Exchange Alternative to Remove ¹³⁷Cs from Low-Curie Salt Waste: Summary of Phase I*, May 2004.
- 2 Peters, T. B., Barnes, M. J., Hobbs, D. T., WSRC-MS-2005-00361, *Strontium and Actinide Separations from High Level Nuclear Waste Solutions Using Monosodium Titanate 2. Actual Waste Testing*, November 2005.
- 3 Herman, D. T., Stefanko, D. B., Poirier, M. R., Fink, S. D., SRNL-STI-2009-00183, *Testing of a Full-Scale Rotary Microfilter for the Enhanced Process for Radionuclides Removal*, January 2009.
- 4 Miller, J. E., Brown, N. E., SAND97-077, *Development and Properties of Crystalline Silicotitanate (CST) Ion Exchangers for Radioactive Waste Applications*, April 1997.
- 5 Lee, S. Y., King, W. D. WSRC-STI-2010-00570, *Thermal Modeling Analysis of CST Media in the Small Column Ion Exchange Project*, October 2010.
- 6 DOE-STD-1189-2008, *Integration of Safety into the Design Process*, March 2008.
- 7 United States Department of Energy, DOE/EIS-0082-S2, *Supplemental Analysis Salt Processing Alternatives at the Savannah River Site*, January 2006.
- 8 Walker, Jr. J. F., Taylor, P. A., Cummins, R. L., Evans, B. S., Heath, S. D., Hewitt, J. D., Hunt, R. D., Jennings, H. L., Kilby, J. A., Lee, D. D., Lewis-Lambert, S., Richardson, S. A., and Utrera, R. F., ORNL/TM-13503, *Cesium Removal Demonstration Utilizing Crystalline Silicotitanate Sorbent for Processing Melton Valley Storage Tank Supernate: Final Report*, March 1998.
- 9 Walker, D. D., WSRC-TR-99-00308, *Cesium Removal from Savannah River Site Radioactive Waste Using Crystalline Silicotitanate Ionsiv IE-911*, September 18, 1999.
- 10 Walker, D. D., King, W. D., Diprete, D. P., Tovo, L. L. Hobbs, D. T., Wilmarth, W. R., WSRC-TR-98-00344, *Cesium Removal from Simulated SRS High Level Waste Using Crystalline Silicotitanate*, October 16, 1998.
- 11 Lee, S. Y., WSRC-STI-2007-00345, *Heat Transfer Analysis for Fixed CST and RF Columns*, July 2007.
- 12 Chew, D.P., Hamm, B. A., SRR-LWP-2009-00001, *Liquid Waste System Plan*, Revision 15, January 2010.
- 13 Chew, D.P., Hamm, B. A., SRR-LWP-2009-00001, *Liquid Waste System Plan*, Revision 16, December 2010.
- 14 Huff, T. H., SRR-SCIX-2010-00045, *Small Column Ion Exchange (Presentation made at the Waste Management Technical Exchange in Atlanta, Ga, on November 16th, 2010)*, Revision 1, November 2010.

15 McKibbin, B. A., S-CHA-H-00010, *Preliminary Consolidated Hazards Analysis for the Small Column Ion Exchange Program*, October 2010.

16 Reed, R. L., SMS-CRT-M-10-00001, *Small Column Ion Exchange Program – Criticality Safety*, September 14, 2010.