

WM2010 Conference, March 7-11, 2010, Phoenix, AZ;

**New Light-Weight Facility Cask for Remote-Handled Waste Disposal at the WIPP Facility,
New Mexico, USA - 10050**

Richard F. Farrell*, Soledad Sifuentes**, and Curtis A Chester**

*U.S. Department of Energy Carlsbad Field Office, Carlsbad, New Mexico 88220

**Washington TRU Solutions LLC, Carlsbad, New Mexico 88220

ABSTRACT

The U.S. Department of Energy (DOE), recognizing the need to address legacy waste accumulated from the development and testing of the atomic bomb and continued development and maintenance of America's nuclear arsenal, finalized the design of what was to become the Waste Isolation Pilot Plant (WIPP). One of the key elements in the disposal process of remote handled waste containers at the WIPP is the use of a cask that shields the radioactive containers to safely dispose of them in a deep geologic repository. Recent changes to disposal rates and a significant reduction in the dose rate level of the waste from levels anticipated when the design of the facility was completed 30 years ago has led to a redesign of the cask. This new Light Weight Facility Cask will handle an estimated 95% of the remote handled waste being sent to WIPP while the existing cask will handle the remaining 5% higher dose rate canisters received. When implemented, the Light Weight Facility Cask will play a key role in support of the National TRU Waste Acceleration Plan and assist in reduction of the Nation's TRU Waste footprint.

INTRODUCTION

In 1978, the newly created U.S. Department of Energy (DOE) recognizing the need to address legacy waste accumulated from the development and testing of the atomic bomb and continued development and maintenance of America's nuclear arsenal, finalized the design of what was to become the Waste Isolation Pilot Plant (WIPP), a deep underground disposal site in evaporite salt in Southeast New Mexico that would permanently dispose of defense-related radioactive waste. The facility is located approximately 40 miles southeast from the city of Carlsbad, New Mexico and sits serenely among other upper Chihuahuan desert features in the southeastern part of the state. The waste identified for the Waste Isolation Pilot Plant was generated by the government beginning in the early 1940's and continued through the Cold War years until the fall of the Berlin Wall in 1989. Today the creation of defense-related radioactive waste continues at a much reduced rate as compared to the Cold War years. It was anticipated that the WIPP would be the first step to resolving the concerns over defense related radiological wastes.

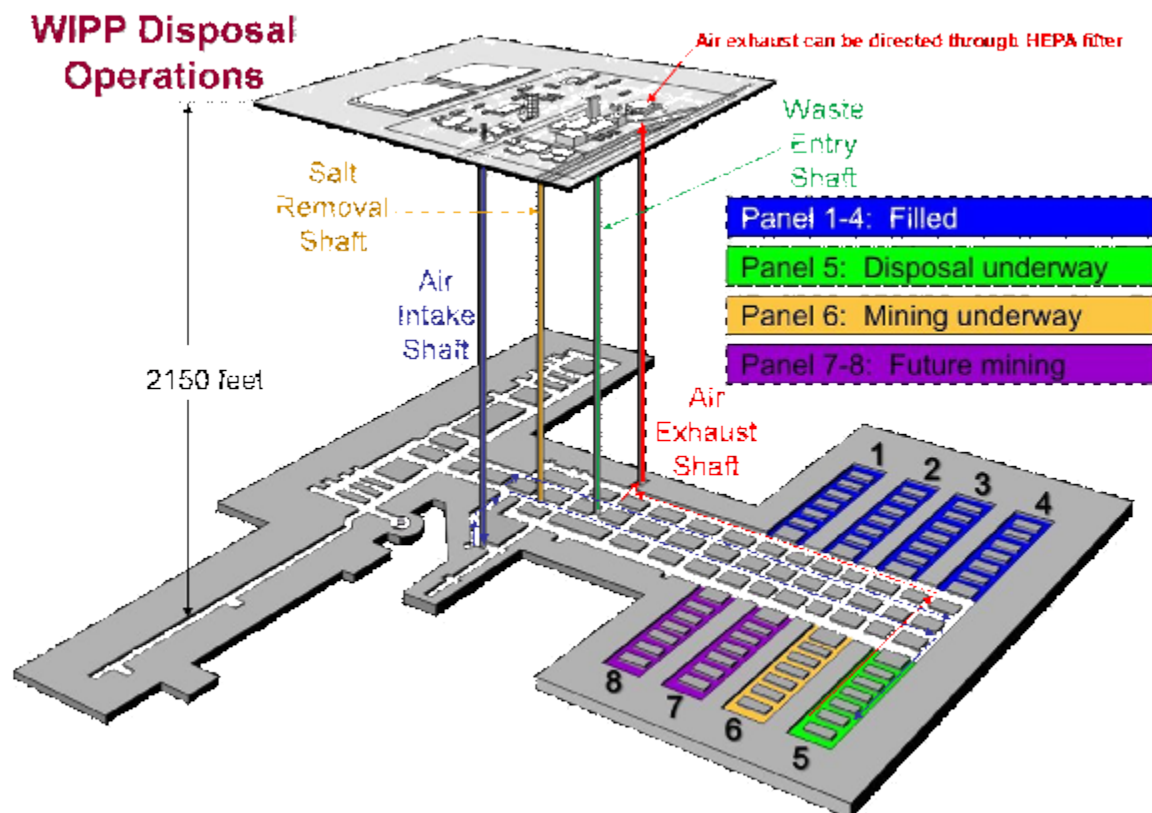

WIPP opened in 1999 with the equipment and facility designed to handle Contact Handled waste and Remote Handled Defense High Level Waste. During the 10 years of operations, DOE and Washington TRU Solutions, the management and operating contractor, has implemented improved operational efficiencies at the WIPP facility. Some of those elements include addressing equipment aging, providing redundancy for waste processing equipment, and re-examining design requirements. Furthermore, evaluations are performed to address consistency between the characteristics of anticipated waste receipts and the original design basis proposed over 30 years ago. The limitations on the type and dose of waste sent to WIPP resulted from years of negotiations with stakeholders and legal agreements with the State of New Mexico.

Waste handling and disposal processes have matured as time has passed. As Remote Handled capabilities have matured, a significant gap has been identified. Waste inventory characteristics and receipt rates have changed from what was expected by original facility design basis and what is currently being received at the facility. The designs of the Remote Handled process included an extremely robust Facility Cask planned to transport and emplace Defense High Level Waste canisters in the walls of the disposal rooms. Those waste characteristics have been revised and the current plan expects to receive 95% of waste canisters with a surface contact dose rate of 100 rem per hour (rem/hr) or less which is orders of magnitude below the earlier expectations. The current process design could be optimized to reduce weight and operational complexity to reduce processing time and maintenance costs. The design of the Facility Cask, the support equipment, and associated shielding is overly conservative. This has required the application of non-standard equipment with high capacities and large footprints that made it difficult to navigate in the restrictive cross sections of the underground repository. Significant cask weight has resulted in excessive wear on support equipment over time. The age of the design has resulted in a

reduction of available spares. The conclusions recommend that an equipment redesign would be beneficial to meet the current facility expectations. As a result, a new cask design has been developed to address maintenance, weight, obsolescence, and overall reliability of the Facility Cask and support equipment.

HISTORICAL OVERVIEW – WIPP AND WASTE CHARACTERISTICS

The WIPP facility is designed for the safe and effective disposal of long-lived radioactive waste. Both legislation, Public Law 102-579, *the WIPP Land Withdrawal Act* [1], and the Stipulated Amendment to the Agreement for Cooperation and Consultation [2], legally binding agreements between the U. S. DOE and the state of New Mexico, limit the waste that may be emplaced in WIPP to defense-related transuranic materials. Those same documents define transuranic waste (hereafter referred to as TRU waste) as material containing more than 3700 becquerels per gram (Bq/g) [100 nano-Curies per gram (nCi/g)] of radioactive elements with atomic numbers greater than 92, the atomic number of uranium (hence, the designation as *transuranic*), and with half-lives greater than 20 years. Putting this into perspective, TRU waste typically contains the most common transuranic element, plutonium-239, which if present at a mass concentration of about 1 part per million, would exceed the 3700 Bq/g bound and be considered transuranic waste.

An early WIPP report, *WIPP Conceptual Design Report* (SAND77, June 1977) [3], prepared by Sandia Laboratories indicates that high-level waste was expected to be handled at WIPP and emplaced in the underground repository although high-level waste has since been removed from consideration for disposal at WIPP. During the early facility design efforts, the high level waste was defined as having average surface dose rates of 7,000 to 10,000 rem/hr as documented in *U. S. Department of Energy WIPP Design Basis Radiological Protection (General)* (Prepared by Bechtel Inc. and issued for client review on November, 1 1978) [4]. However, the WIPP operational concept including the handling and underground emplacement of high-level waste continued to be considered by facility planners into the early 1980s as documented in the *WIPP Environmental Impact Statement* (DOE/EIS-0026, October 1980) [5] which identified high-level waste inventories planned for inclusion in WIPP operations.

At WIPP, Contact Handled waste and Remote Handled waste are processed for disposal in the deep geologic repository. Remote handled waste is classified as such based on the surface dose rate of an unshielded payload container that is shipped to WIPP. The definitions of contact- and remote-handled TRU waste are legislated in the WIPP Land Withdrawal Act. Waste processed as Contact-Handled TRU waste is in a container with a surface contact dose rate not greater than 2 millisievert/hour (mSv/hr) [the equivalent of 200 millirem per hour]. Waste processed as Remote-Handled TRU waste is in a container with a surface contact dose rate greater than 2 mSv/hr [greater than 200 millirem per hour]. Contact-Handled waste disposal operations had been successfully underway since March 1999. WIPP received regulatory authorization from the U.S. Environmental Protection Agency (EPA) and the state of New Mexico October 17, 2006 to begin underground emplacement operations for Remote Handled disposal into the repository.

Pursuant to the *Documented Safety Analysis (DSA)*, (DOE/WIPP 07-3372, Revision 1, February 19, 2009) [6], the 2 mSv/hr (or 200 millirem per hour) dose rate limit or dividing line between contact and remote handled waste is a design requirement in the system design description of the existing Facility Cask. The cask is used at WIPP in remote-waste handling operations. The current DSA states that, “The facility cask is designed to provide shielding for a Remote Handled waste canister such that the cask surface dose rate is less than 200 millirem/hr

[2 mSv/hr] when the waste canister surface dose rate is 7000 rem/hr [70 Sv/hr].” The design basis for the existing Facility Cask shows that it will safely hold up to a 71-cm diameter, 338 cm long overpack.

The current statutory dose rate limit for remote-handled TRU waste disposed at WIPP is 10 Sv/hr (as legislated in the *WIPP Land Withdrawal Act*) which is much less than the assumed dose rates of early design basis documents that included Defense-High-Level-Waste. Thus, the design of the existing Facility Cask is overly conservative for the current limits imposed. The TRU Waste Acceleration Plan contains lower weight and lower dose rate payloads than originally considered, making the existing cask inefficient for high receipt rates.

Building on past processing and disposal operations at WIPP, remote-handled TRU waste receipts are increasing and expected to continue to increase in the future. Around the clock, 7 days a week, remote-handled TRU waste is received at WIPP from nuclear waste generator and storage sites across the country and subsequently emplaced for disposal in the underground. The receipt of waste at WIPP begins by accepting Remote-Handled TRU waste transported to WIPP in shielded road casks carried on semi-tractor trailers. Casks are inspected for external contaminants upon receipt, and then moved to the Remote-Handled Waste Handling Bay processing area where the road casks are unloaded from the semi-tractor trailers. Inside a shielded processing area, canisters are removed from road casks using processing equipment that is operated remotely and transferred to the shielded Facility Cask. The loaded Facility Cask is transported to the underground disposal area that is approximately 655 meters below the surface. Horizontal boreholes in the solidified salt become the final disposal location within the array of panels and rooms in the underground repository.

CONCERNS REGARDING RELIABILITY

From the time the Remote Handling facility was completed (approximately late 2001) until completion of a Performance Dry Run for the remote handled process in 2002, a combination of waste characteristic changes, age, environmental conditions, and revisions to TRU Waste Acceleration plans has resulted in reliability concerns for the Remote Handled equipment. The Facility Cask became the focus of those equipment reliability concerns. While these concerns were being evaluated, it was determined by the Department of Energy that the Remote Handled process would not be engaged for some time. Equipment maintenance was reduced, equipment was placed out of service, and evaluations were placed on hold. In 2005, the Remote Handled process was re-initiated and equipment evaluations were conducted to address the previous concerns including reliability and applicability to the processing conditions and receipt rates established for that time.

The remote-handled equipment was designed to meet specific design basis requirements for high level waste. In particular, the existing Facility Cask and the existing Horizontal Emplacement and Retrieval Equipment (HERE) were designed to be unique to meet specific shielding requirements. The existing cask was designed to house containers weighing up to 4550 Kg. As the payloads became lighter, the expectation arose that more could be handled in the same time frame but no changes were made to the Facility Cask design or method of operation to support the expectation of increased processing rates.

When the evaluation was completed it revealed that the aged design and previously planned method of operation of the equipment particularly for the Facility Cask would result in reliability

concerns. In addition, the Facility Cask and other equipment were nearing the end of their design life and many had lost logistic (spares) support. This was due in part to technological advances that rendered older components obsolete, costly to fabricate compared to newer designs, and vendor support ceased for those items. It was determined that several pieces of equipment would need to be redesigned and new fabrications provided to address reliability concerns and support acceleration of Remote Handled TRU waste receipts. Particularly, the Facility Cask had several concerns including the current lower dose rate, waste receipt rates, weight issues that provided excessive wear on support equipment, equipment interfaces, and component availability for spares. Additionally, design requirements for support equipment would have to be revised to allow the use of standard equipment rather than custom designed equipment for cask transport. As part of the evaluation, an effort was made to reduce the large footprint of the support equipment that makes it difficult to maneuver in the restrictive cross sections of the underground repository (See Fig. 1.)



Fig. 1. 41-Ton Forklift going around a corner in the underground repository

RESOLVING RELIABILITY ISSUES

Through August 2009, 95 percent of the canisters of remote-handled TRU waste received at WIPP have exhibited a surface dose rate of less than 0.1 Sv/hr, and only a handful have approached 1 Sv/hr (See Fig. 2.). Estimates of likely future remote-handled waste planned to be disposed of at WIPP indicates that surface dose rates of future canisters will be very similar to those already exhibited by the 300 canisters already disposed of at WIPP. Design and fabrication of the LWFC is one way to address reliability concerns while improving remote waste handling process efficiency. In 2008, a design activity was performed to address the reliability concerns previously expressed. Among the reliability concerns addressed were shielding requirements, method of operation, weight issues, equipment interfaces, and standardization of components with commercially available items. Additionally, criterion was developed to address design requirements for support equipment to provide equipment that is more maneuverable in the restrictive cross sections of the underground repository. These items are discussed in detail in the following section.

During the process of the redesign it was decided that the new LWFC would be the applicable cask for the greater population of Remote Handled waste (95%) where the canister surface dose

rate was less than 1 Sv/hr. The existing Facility Cask will be maintained to handle the occasional high dose rate Remote Handled shipment that will need the more robust shielding in the future. This also provides equipment redundancy with two casks available instead of one for the greater population of canisters.

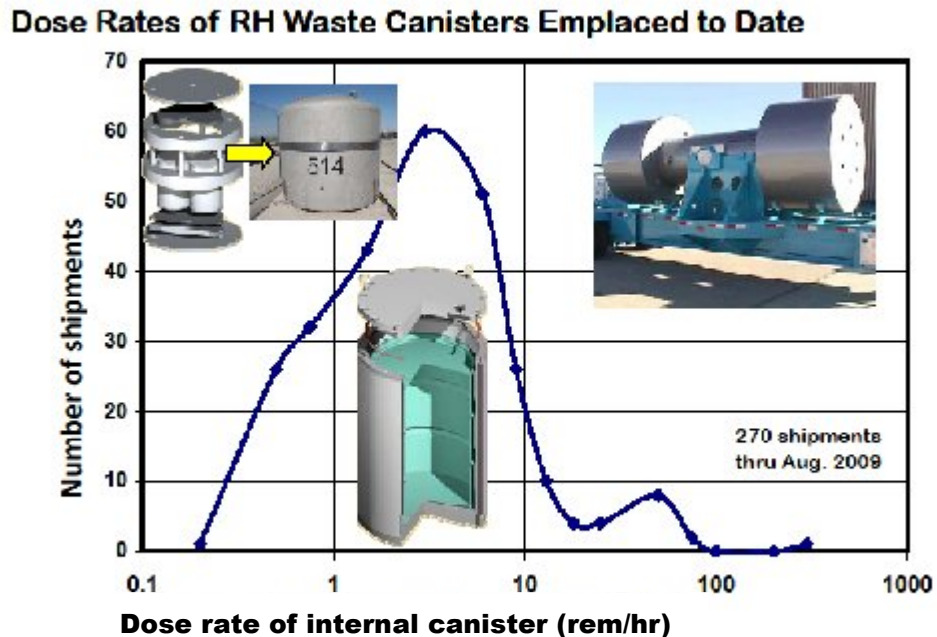

Fig. 2. Historical dose rate for canisters received at WIPP

DESIGN OF THE LIGHT WEIGHT FACILITY CASK

Washington TRU Solutions LLC (WTS), the WIPP managing and operating contractor, procured the design of the new LWFC from a qualified engineering and design firm. The procurement of the LWFC was a competitive procurement and completed in early 2009. Five potential offerors submitted proposals to manufacture the LWFC. A qualified fabricator was chosen to manufacture the LWFC. Fabrication will begin in December 2009 and completion and delivery to the WIPP site is expected by August 2010.

The design established the use of the LWFC to be limited to canisters with a surface contact dose rate of 1 Sv/hr or less. The design also addresses reliability concerns including shielding requirements, method of operation, weight issues, equipment interfaces, and standardization of components with commercially available items.

As a result of the design outputs, criteria were developed for the support equipment that are more suitable for use in the restrictive cross sections of the underground repository. Throughout the design phases WTS design authority provided oversight to ensure the reliability concerns were addressed. (See Fig. 3.).

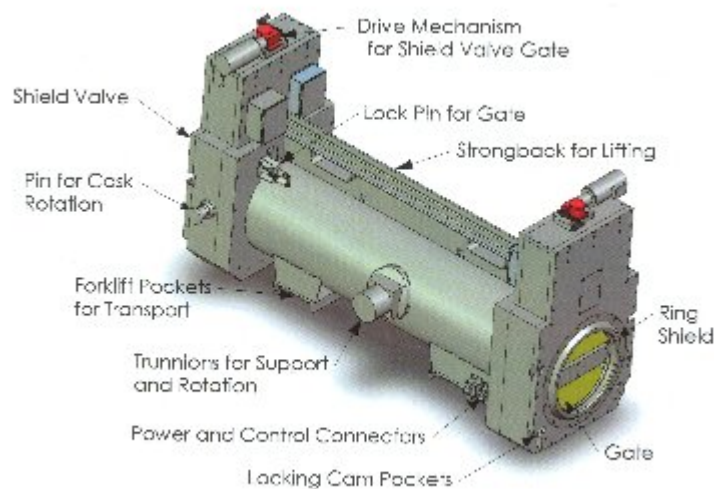

Fig. 3. Light Weight Facility Cask

Shielding Requirements

As previously established, the Facility Cask design was sufficiently robust to support processing of Defense High Level Waste but was considered extremely conservative for TRU waste as allowed by the Land Withdrawal Act. The current Facility Cask is large and heavy. One method of weight reduction would be to evaluate the shielding requirement compared to the reduced canister surface dose rates currently planned for shipment to WIPP. It was established that 95% of canisters would maintain a surface dose rate of 1 Sv/hr or less. The remaining 5% could be between 1 and 10 Sv/hr. It made sense that the majority of the process time would be spent on the larger percentage population of canisters.

A reduction in size was also considered but the LWFC still had to interface with existing equipment and existing canisters. Due to the construction of the facility and interfacing equipment, the length and inner diameter could not be changed. In addition, generator sites currently maintain an inventory of approved canisters whose geometric dimensions require similar consideration.

The Radiological Engineering group established a design attenuation factor of 1/10,000 for the new LWFC in order to meet the ALARA requirement as per 10 CFR 835. The attenuation factor is defined as the ratio of the incident dose rate to the dose rate transmitted through a shielding material. The attenuation factor is itself driven by the ALARA design review for the LWFC design which states that attenuation factors less than 1/10,000 would be ALARA but must be more than 1/1,000. Values within a factor of two of the more conservative 1/10,000 attenuation factor are deemed adequate to meet these criteria such that the results of the analysis remain consistent with the ALARA design review criteria. Once the design was completed, a shielding analysis was performed and showed that the attenuation factor would be met with the design. The initial analysis evaluated only the radial shielding of the lead cylinder and the shield valves. It did not consider streaming paths through penetrations from the cask body and shield valves that could be of concern during emplacement operations. A Monte Carlo analysis was then applied to address streaming concerns as well. The Monte Carlo analysis considered two specific penetration configurations with a loaded remote handled waste canister being the source

term and utilizing Cs-137. The material modeled in the waste canister was taken from the baseline inventory report as an average over all the waste streams. One configuration analyzed is the LWFC loaded with a waste canister in the vertical position. The other configuration analyzed is the interfacing of the LWFC and the Alignment Fixture Assembly (AFA) shield valve on the emplacement machine with the waste canister at an intermediate location within the cask body and across the AFA shield valve assembly as the canister is pushed into the borehole (See Fig. 4.).



Fig. 4. Facility Cask mounted on the HERE at the disposal borehole

The analysis resulted in enhancements to some of the shielding component in very localized areas. The thickness of the top plate on the shield valves was increased. The rails on the shield valves were extended to provide additional shielding at the bottom of the shield valve where the pockets are located for the shield valve clamps. The shielding lead pockets were enlarged. The shield valves at the clamp pockets were made longer and deeper to ensure that enough shielding was provided to compensate for the metal removed for the clamp pockets. The switch cover plates on the shield valves were thickened. In all, the enhancements did not add significant weight to the overall assembly. The Monte Carlo analysis was performed again on the enhancements and concluded that the shielding modifications were adequate to meet the ALARA requirements and would not result in additional inefficiencies for remote handled waste emplacement operations.

Method of Operation

The LWFC resembles the existing cask because it has the same basic subassemblies including a concentric steel cylinder housing that has shield valves on both ends that operate like a gate valve. From the control panel operations on the surface and in the underground, it will operate the same way as the existing cask. Essentially, it has the same fit, form, and function.

The body inner diameter is the same. The inner and outer shells are both the same material thickness as the existing cask but the lead annulus was reduced to accommodate appropriate shielding material. The LWFC is equipped with features similar to the existing cask to be positioned, oriented, and transported using the existing equipment.

The locking pins on the existing Facility Cask shield valves were revised. Pneumatically operated solenoids were used to engage locking pins on each shield valve to lock the doors in the open or closed positions. The lock pins must activate correctly before the shield valves will activate. Age and environment have introduced operational issues. The dirty salt environment contributes to additional delays in the emplacement process. After enough salt and dirt have been introduced to accumulate onto the mechanism, the additional friction would eventually result in a condition where the pneumatics would not completely overcome the accumulated resistance, resulting in partially retracted lock pins. With a loaded Remote Handled canister inside the Facility Cask, maintenance may be challenging for worker safety and from the perspective of observing Technical Safety Requirements.

The LWFC new shield valve assemblies and lock pin actuation design has been enhanced. The components are enclosed and protected from the dirty environment. In addition, an electric solenoid retraction mechanism is used to actuate the pins. The electronic system has advantages over the compressible air used in a pneumatic system.

The existing Facility Cask top and bottom shield valve gates are motor operated through a gear box, pinion, and bull gear with a separate torque limiter. The existing cask also has an override that is cumbersome to use in the event of valve failure and difficult to access. In addition, the override was operated by a ratchet with no braking feature allowing the jack screw to spin freely. The LWFC design incorporates a direct drive system for the gates that includes an electric brake motor to power the screw jack and an integrated torque limiter and manual override. The gear box, bull gear, and pinion gear have been eliminated from the drive components. When needed, the gates may be opened using the manual overrides that have easy access and built in controls to prevent "free-wheeling" of the screwjack.

Other functional improvements include a distributed control feature to support minimizing control connections by transmitting control wirelessly, thinner lead shielding thickness, improved interface design between the cam pockets and the cam locking mechanism. For manufacturing purposes, dimensional tolerances were increased and more non-destructive examinations were added to the structural welds that connect the cylindrical body to the shield valve inner plate. The shield valve side plate bolting was increased to provide a conservative design and to reduce the likelihood of damage that could occur to the countersinks during operation and maintenance.

Weight Issues

The LWFC empty weight is 20,640 Kg as compared to the 30,770 Kg weight of the existing Facility Cask. The design of the LWFC incorporated sufficient structural integrity to sustain an impact load of 1g in the horizontal direction and 13 g in the vertical direction. The strongback and the base support are structurally adequate to support lifting and transporting the LWFC. The trunnions located on both sides of the Facility Cask have adequate capacity for supporting and rotating the LWFC. The shield valve locking pins were designed to be adequate for shear and flexural capacity to support the weight of the door. The shield valve is structurally adequate to support the weight of the canister when the cask is in the vertical position.

Facility and Equipment Interfaces

The overall length, diameter, trunnion locations, bore centerline, and forklift pocket locations of the LWFC will allow a consistent interface with the existing WIPP facility, systems, and equipment. Only the height varies from the existing cask with the LWFC being about 15 cm shorter than the existing cask. The underground facility is mined into a salt layer with a large areal extent. The mine is continually closing in on itself. The roof of the tunnel in particular poses concerns as it sags into the drift due to the rock pressures. As time goes on, the pressures cause the rock to sag into the void of the tunnel. During activities requiring lifting of the Facility Cask, the cask comes close to the roof (See Fig. 5.). At times the sag in the roof must be brought down to allow for continued operations. The scaling operation halts Contact Handled and Remote Handled waste handling activities for a time. The reduced height of the Facility Cask will prolong the roof scaling interval and reduce the adverse impact to processing rates.



Fig. 5. Facility Cask being lifted from the transfer car near roof

Standardization of Components with Commercially Available Items

The LWFC mechanical and electrical operational components have been selected from commercially available components. Some of the unique items include fabricated items such as the body, shield valves, shield valve housings, and lock pins. Some additional commercial components include a heavy duty stainless steel track roller, solenoids, screw jacks, ball nuts, bearings, reducers, motor, switches, electrical connectors, and fasteners. The heavy duty stainless steel track roller is used to resist the operational forces of the valve gate during static and dynamic loading when the cask is in the vertical and horizontal orientations. The screw jack is a heavy duty 122 cm long screw with a 24:1 gear ratio, requiring for its operation a 1-1/2 hp brake motor.

Support Equipment Criterion

The LWFC has been designed to interface with the Facility Cask Transfer Car, Facility Cask Rotating Device, Grapple Shield Bell, Telescoping Port Shield, Waste Hoist Conveyance, Horizontal Emplacement and Retrieval Equipment (HERE), and the Underground Facility Cask Transporter (37 metric ton forklift). As a result of the design outputs, criterion was developed to address design requirements for support equipment. The key improvement of the new cask is its

reduced weight and optimization of operational methods. The LWFC weighs 20,640 kg, which is 10,130 Kg less than the existing cask. The reduced weight of the LWFC will result in less abnormal wear and tear on numerous pieces of equipment used in the waste handling process.

Transport equipment such as the transfer car and forklifts will interface with the existing cask and the LWFC. Some equipment will be evaluated for replacement where there is an identified advantage in maneuverability, maintenance, or to address age related issues. A noteworthy candidate for replacement is the 37 metric ton forklift due to age, maneuverability, size, and other factors. The weight reduction of the LWFC will assist in selecting a forklift that is smaller in size and more maneuverable in the restrictive underground facility. Age and resulting spares obsolescence will be addressed as well.

The LWFC is conveyed to the underground on the waste hoist. Occasionally, a bonnet located on top of the conveyance has to be removed if the weight capacity is exceeded. With the lighter load of the LWFC, removal of the bonnet is not likely needed for waste downloading. The reduction in the Facility Cask weight will allow for transfer of the fully loaded LWFC to the underground without additional measures thereby reducing processing time for the largest population of canisters.

The Facility Cask Rotating Device is used to rotate both the Facility Cask and the LWFC to a vertical position for canister loading. For the LWFC, it is expected that the reduced weight will result in less strain on the rotating device's hydraulic system while it is rotated into the vertical position. The Facility Cask Transfer Car is used to convey either cask from the Facility Cask Rotating Device on the surface to the underground staging area after the cask has been loaded with a remote-handled waste canister and rotated to a horizontal orientation. The reduced weight of the LWFC will result in less strain on the wheels of the Facility Cask Transfer Car.

Functionally, the LWFC will provide and maintain radiation shielding and serve as a secondary container for Remote Handled waste canisters during their transportation through the WIPP facility and to the underground repository for emplacement. Remote interface is required during the process to provide power and control with the cask. Passive and active facility shielding, controls, and status signals are present during transfer of the Remote Handled waste canisters into and out of the cask. A programmable logic input/output panel simplifies connections between the new Facility Cask and existing equipment. These controls provide reliable power and control connect and disconnect capability further reducing process time. All of these operational considerations result in an efficient Facility Cask more suitable to the new application. (See Fig. 6.)

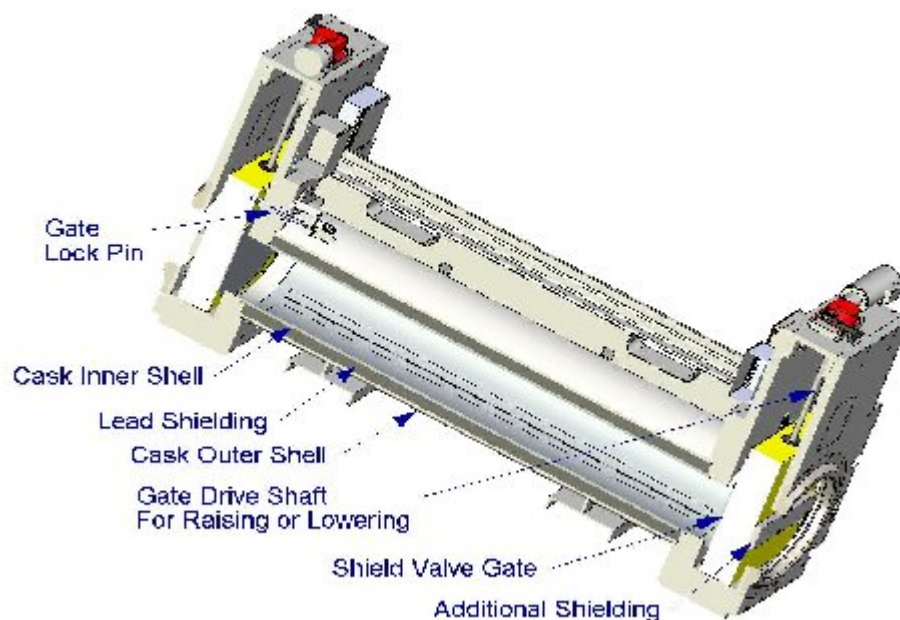

Fig. 6. Light Weight Facility Cask cross-section

BENEFITS OF THE LIGHT WEIGHT FACILITY CASK

Overall, the new design features incorporate current technology into a robust Facility Cask that will support receipt rates in excess of 6 canisters per week. The robust design addresses process and reliability concerns that have grown with the age of existing equipment and provide redundancy by addressing a single point failure within the remote-handled TRU waste handling processing. The key improvements of the LWFC are its proper shielding, reduced weight, operational redesign, and updated hardware and components. A weight reduction of 10,130 Kg. will place lighter burdens on numerous pieces of equipment used in the waste handling process reducing wear and tear. In addition, the LWFC will provide reduced stress to the 37 metric ton forklift components, seals, tires, and lifting components, as it travels across the uneven mine floor. This is expected to result in reduced wear on the forklift components with the benefit of less maintenance downtime and longer equipment life. In addition, the leveling jacks on the Horizontal Emplacement and Retrieval Equipment (HERE) will be subjected to lighter load when the LWFC is placed on the HERE, providing less wear and tear on its hydraulic jacks and structural components.

The LWFC design will address existing reliability concerns by providing redundancy to a single point failure. The existing Facility Cask is a one-of-a-kind item creating a single point for failure in the waste handling process. When it experiences planned or unplanned maintenance, the remote-handled process cannot be sustained. As the existing Facility Cask ages there is an increased likelihood that equipment failures attributable to wear and tear such as cable pin breakages, shield valve component jams, and locking pin mis-alignment issues may increase. Sustained use of the existing cask at current receipt rates causes stress on existing equipment not originally intended by design and will result in additional maintenance. Increases in

maintenance activities will increase interruptions in the waste emplacement and impact scheduled operations. To mitigate this adverse impact, the LWFC will provide functional equipment redundancy.

Because about 95% of the remote-handled waste that arrives at WIPP will have a dose rate of less than 1 Sv/hr, implementation of the LWFC will increase operational efficiency. The current efficiencies that are addressed by the LWFC include smaller sized support equipment, downtime due to unplanned maintenance on single point failure equipment, and reduced maintenance durations.

The implementation of the LWFC will not require equipment as large or as high in capacity and minimize specialty equipment. Most notably the underground transport (forklift) used to convey the current Facility Cask to the emplacement room is very large and fills a large amount of the cross-section of the underground path (drift). A reduction in payload weight by using the LWFC will result in the need for a lower capacity and smaller sized forklift.

Finally, many of the components on the existing Facility Cask are durable but reaching the end of their design life. With aging of the existing cask, the frequency of failure for certain components may increase, and because the Facility Cask is an one-of-a-kind remote-handling component, each maintenance outage will result in unanticipated downtime and negative processing impacts. The LWFC design incorporates standardized components in the design giving reliability a higher priority. Additionally, critical spares are being identified for the LWFC to address which components are likely to fail during use including wear elements, long-lead items, and critical elements to shielding.

CONCLUSION

Evaluations of processes and equipment for beneficial operation are typical of the commitment at WIPP to improve operations based on experience and sound operations and engineering judgment. The elements addressed in this evolution were critical to increasing overall benefit to the customer and the public by providing the ability to sustain increased processing rates. With approximately 95% of the Remote Handled TRU waste being handled by the Light Weight Facility Cask, it is expected to produce less wear and tear on all support equipment, reduce processing time, increase the availability of equipment, and reduce maintenance costs. When implemented, the Light Weight Facility Cask will play a key role in support of the National TRU Waste Acceleration Plan and assist in reduction of the Nation's TRU Waste footprint.

References

1. Public Law 102-579 “Waste Isolation Pilot Plant Land Withdrawal Act” as amended by Public Law 104-201 (H.R. 3230, 104th Congress)
2. Stipulated Amendment to the Agreement for Cooperation and Consultation
3. “WIPP Conceptual Design Report” (*SAND77*, June 1977), prepared by Sandia Laboratories, Albuquerque, NM 87115 and Livermore, CA 94550
4. “U. S. Department of Energy WIPP Design Basis Radiological Protection (General)”, Issued for client review on November, 1 1978 and prepared by Bechtel Inc., San Francisco, CA
5. “WIPP Environmental Impact Statement” (*DOE/EIS-0026*, October 1980), prepared by the U. S. Department of Energy, Albuquerque, NM
6. Documented Safety Analysis (DSA), (*DOE/WIPP 07-3372, Revision 1*, February 19, 2009)