

Evaluating the Performance of ASME AG-1 Section FK Radial Flow Filters – 10015

Michael S. Parsons, Charles A. Waggoner, and R. Arunkumar
Mississippi State University
Institute for Clean Energy Technology
205 Research Blvd, Starkville, MS 39759 USA

ABSTRACT

The American Society of Mechanical Engineers (ASME) Code on Nuclear Air and Gas Treatment (AG-1) has recently added Section FK establishing requirements for radial flow filters. Section FK filters are scheduled to be a major element in the HEPA filtration system of a Department of Energy (DOE) facility. Radial flow filters have been used in Europe for some time, however, a limited amount data exists with respect to the performance of the new FK units. The Institute for Clean Energy Technology (ICET) at Mississippi State University (MSU) has conducted an initial set of tests with respect to the performance of these filters utilizing carbon black as the challenge aerosol. Filters were tested by ICET as either single units (2000 cfm (56.63 m³/min)) or as dual units (4000 cfm (113.3 m³/min)). The challenge aerosol was fully characterized with respect to particle size distribution. Data collected for each series of tests were mass median diameter, count median diameter and number density of the challenge aerosol. The most penetrating particle size (MPPS) of the filter was also determined.

INTRODUCTION

HEPA filters are commonly employed to control particulate matter (PM) emissions from processes that involve management or treatment of radioactive materials. Facilities within the US Department of Energy (DOE) complex are particularly likely to make use of HEPA filters in the processing of exhaust gases prior to release to the environment. In May of 1999 the Defense Nuclear Facilities Safety Board (DNFSB) released Technical Report 23 entitled *HEPA Filters Used in the Department of Energy's Hazardous Facilities* [1]. This report expressed concerns for the potential vulnerability of HEPA filters used in vital safety systems. Later that same year DOE initiated a response to the DNFSB's Recommendation 2000-2 [2] by implementing measures with regard to 100 percent quality assurance testing of HEPA filters and a review of vital safety systems in general [3]. DOE's actions in this matter were also timely with regard to concerns being voiced by citizen groups over the performance of HEPA filters and how their functional status is monitored. Of particular concern are the threats to HEPA filter performance posed by water and smoke.

For the past several years, the Institute for Clean Energy Technology at Mississippi State University has conducted extensive research under its DOE sponsored HEPA Filter Monitoring Project. Studies with 12"x12"x11.5" (30.5 cm x 30.5 cm x 29.2 cm) American Society of Mechanical Engineers (ASME) Code on Nuclear Air and Gas Treatment (AG-1) Section FC HEPA filters have included moisture failure, source term loading, seal and pinhole leak tests, and media velocity. Details related to design, construction, and operation of the test stand utilized in these research efforts have been published [4]. Discussion of the experimental design related to

these research efforts as well as results has been presented at numerous conferences [5, 6, 7] and published [8]. These discussions include aerosol generation, filters tested, and aerosol measurement instrumentation utilized.

ASME AG-1 has recently added Section FK establishing requirements for radial flow HEPA filters. Section FK HEPA filters are scheduled to be a major element in the HEPA filtration system of a Department of Energy (DOE) facility. Radial flow HEPA filters for nuclear facility applications have been used in Europe for some time, however, a limited amount data exists with respect to the performance of the new Section FK units. Of particular concern is the lack of particle loading and structural failure data for the radial flow HEPA filters planned for the DOE facility. The DOE facility currently assumes that the previous loading data will be applicable to the slightly different filter design in the facility's filters. The facility also assumes that the new radial filters will not have structural failures below 10 inches water column (10 in. w.c. (2.5 kPa)) under humid conditions. These assumptions will be verified in the present test plan.

ICET is developing a larger-scale HEPA filter test stand to evaluate the performance of one to four 1000 CFM (28.32 m³/min) AG-1, Section FC, axial flow filters or up to two 2000 CFM (56.63 m³/min) AG-1, Section FK, radial flow filters at rated flow velocities and to differential pressure levels of 30 in. w.c. (7.5 kPa).

Activities to be conducted during 2009 include design and fabrication of new test stand, characterization of its performance, and challenging facility representative radial flow HEPA filters with various simulants. The test stand and auxiliary equipment will include the capability of challenging filters with smoke, soot, high moisture levels, and high temperatures. This test plan has been developed through collaborations with representatives from the DOE facility and representatives from the DOE National Nuclear Security Administration (NNSA) responsible for reviewing DOE-STD-1066-99 "Fire Protection Design Criteria".[9]

ISSUES

Information from public literature currently serves as basic guidance used by engineers to evaluate the potential impact of fires and other events involving abnormally high filter loading rates on HEPA filters employed in confinement ventilation systems and process gas treatment [10, 11]. Bergman's model of HEPA filter plugging [10, 11] has been successfully used in designing the HEPA filtration systems in other DOE facilities. Other models are either limited to a single application or do not have sufficient parameters for practical analysis. For example, Ballinger's paper [12] describes HEPA filter plugging in reprocessing facilities and is limited to filter plugging by kerosene fires. The paper by Beyler [13] describes filter loading in terms of an empirical second order polynomial but has no filter or particle parameters in the equation. Despite the success of the Bergman model for early stage HEPA filter plugging it still requires experimental data for the empirical constants in the equation. Thus experimental data is needed to assess filter plugging for any new filter design and account for effects of particle size for either depth vs. surface loading or bridging between filter media pleats.

Experimental data from Loughborough [14] in the public literature is currently used with Bergman's model by engineers at the facility in the design and development of confinement

ventilation and process gas treatment systems for control of particulate matter emissions. Loughborough at AEA Technology Harwell Laboratory in the UK conducted tests challenging radial flow HEPA filters with carbon black over two decades ago. The primary problem with the data is that it was obtained on slightly different filters than will be used at the facility. This scope of work will include testing with the proper HEPA filter to provide data to engineers at the DOE facility and confirm or correct the filter loading and failure assumptions. Loading tests of facility representative radial flow HEPA filters will be conducted using carbon black, alumina powders and Arizona road dust as compared to the two aerosols (carbon black and sodium chloride) used in the Loughborough study. In addition to the use of a wide range of particle sizes, the ICET tests will also include variable humidity. Loaded filters will be autopsied to provide empirical data for comparison to modeling results.

RESEARCH TEST PLAN

Test Procedure and Test Matrix

Facility representative radial flow HEPA filter testing will be conducted on the ICET large-scale filter test stand which is illustrated in Figure 1. Standard test conditions will be ambient temperature ($\sim 70^{\circ}\text{F}$ (21.1°C)), and humidity ($\sim 50\%$), and these parameters are controlled. The test stand will use the building air for its inlet air and will discharge the exhaust to the outside which will place an additional load of 2,000 cfm ($56.63\text{ m}^3/\text{min}$) on the building air supply. The impact of this additional load on the building air supply has not yet been assessed, but it is not expected to adversely affect the planned filter tests because little if any humidification or dehumidification will be needed for the building air. During the planned test period, the test temperature and humidity is expected to be within $60\text{--}80^{\circ}\text{F}$ ($15.6\text{--}26.7^{\circ}\text{C}$) and $40\text{--}50\%$ RH respectively. Both parameters will be recorded for all tests.

A series of eighteen facility representative radial flow HEPA filters will be tested in this test plan as described in the test matrix given in Table 1. Only one facility representative radial flow HEPA filter will be tested in the test housing at a time, eliminating the concern with non-uniform airflow distribution and particle mixing uniformity in the housing. The test set 1 loading represents the particle loading under ambient temperature and moisture conditions. Although the normal practice in the facility will be to replace the HEPA filter at 4 in. w.c. (1 kPa), the loading will be continued to the maximum system dP of 30 in. w.c. (7.5 kPa) to determine structural failure. The test set 2 loading represents normal filter loading up to the replacement point at 4 in. w.c. (1 kPa) followed by a simulated accident of high moisture and high temperature.

The facility has two slightly different radial flow HEPA filters. One filter design, (safe change) is used for hands-on applications, and the other (remote change) for remotely handled applications. Both designs will be used. The “remote change” HEPA filter is expected to have a lower particle loading capacity than the “safe change” HEPA filter.

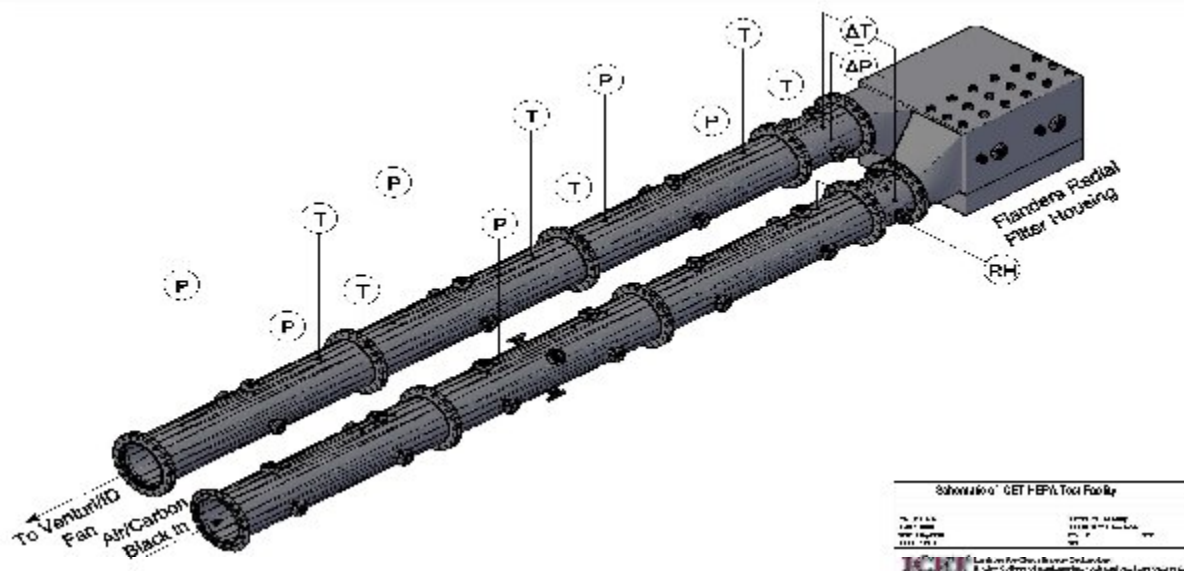

Figure 1. Drawing of test duct and housing.

Table 1. Test Matrix for Single Facility Representative Radial Flow HEPA Filter.

Test Parameters and Guidelines:		Aerosol #1 0.25 μm (Alumina)	Aerosol #2 2.0 μm (Carbon Black)	Aerosol #3 10.0 μm (AZ Road Dust)	
Remote Change HEPA Filter	Data Set 1	Test Set 1 – Inlet air controlled to 40-50% RH. Test until maximum dP and/or failure is reached	Filter 1	Filter 2	Filter 3
		Test Set 2 – Inlet air controlled to 40-50% RH until filter reaches 4 in. w.c. (1 kPa), then add air at 165-170 °F (73.9-76.7 °C) and 95-100% RH for maximum duration. Test until maximum dP and/or failure is reached	Filter 4	Filter 5	Filter 6
Remote Change HEPA Filter	Data Set 2	Test Set 1 – Inlet air controlled to 40-50% RH. Test until maximum dP and/or failure is reached	Filter 7	Filter 8	Filter 9
		Test Set 2 – Inlet air controlled to 40-50% RH until filter reaches 4 in. w.c. (1 kPa), then add air at 165-170 °F (73.9-76.7 °C) and 95-100% RH for maximum duration. Test until maximum dP and/or failure is reached	Filter 10	Filter 11	Filter 12
Safe Change HEPA Filter	Data Set 3	Test Set 1 – Inlet air controlled to 40-50% RH. Test until maximum dP and/or failure is reached	Filter 13	Filter 14	Filter 15
		Test Set 2 – Inlet air controlled to 40-50% RH until filter reaches 4 in. w.c. (1 kPa), then add air at 168 °F (75.6 °C) and 97% RH for maximum duration. Test until maximum dP and/or failure is reached	Filter 16	Filter 17	Filter 18

Tests will be conducted on the facility representative radial flow HEPA filters using three different test aerosols. Carbon black powder (CanCarb N991 thermal carbon black powder) with a mean particle size of 280 nm and mass median diameter (MMD) of ~2μm will be utilized as one challenge aerosol. Alumina, Al(OH)₃, with an aerodynamic mass median diameter of 0.3

μm will be the second aerosol used in these tests. The third aerosol to be used will be Arizona Test Dust ISO 12103-1 A1, Ultrafine Test Dust, Powder Technology Inc, or an equivalent test simulant for 5-10 micron size. Test stand flow rates used will be 2000 cfm ($56.63 \text{ m}^3/\text{min}$) $\pm 0 - 10\%$ for single facility representative radial flow HEPA filters. The filters will be intermittently loaded until the desired pressure drop is obtained or until the end of a workday is reached. It will take about 4,000 g of the Arizona test dust, 1,000 g of the carbon black and about 150 g of the alumina to reach 10 in. w.c. (2.5 kPa) of pressure drop. Another 30 – 50% of this mass is expected to load the filters to 30 in. w.c. (7.5 kPa) of pressure drop or to the rupture point. Aerosol concentrations for the different aerosols will be adjusted to complete a filter loading within three days.

Aerosol concentration will be measured upstream of the filter(s) utilizing three instruments: (1) Scanning Mobility Particle Sizer or SMPS (TSI Model 3936), (2) Aerodynamic Particle Sizer or APS (TSI Model 3321), and (3) Electrical Low Pressure Impactor or ELPI (Dekati). In addition, an inertial impactor will be used to characterize the aerosol mass size distribution to provide comparable measurements to previous loading studies. Since the filter loading consists of measurements of pressure drop as a function of particle mass accumulation, all particle size measurements will be converted to a mass-size distribution. Downstream particle concentration and size will be measured with a Laser Particle Counter or LPC (Particle Measuring System Model LPC-0710) and a Condensation Particle Counter or CPC (TSI Model 3010) for the initial part of the loading until the concentration becomes vanishingly small. In addition, a photometer will be used downstream of the filter to detect filter tears and collapse at the later stages of filter loading above 10 in. w.c. (2.5 kPa) until the point of collapse or at the maximum 30 in. w.c. (7.5 kPa). The photometer will be referenced to the upstream challenge concentration to provide a relative percent penetration. The effect of high humidity on the particle size distributions and concentration measurements will be determined in calibration tests.

The particle loading tests will consist of initially weighing the filter, recording pressure differential, loading the filter to prescribed pressure drops of 4, 7 and 10 in. w.c. (1, 1.7, and 2.5 kPa) and weighing the filter at each of these pressure drops. Photos of the particle deposits will be taken at each weighing. The filter will then continue to be loaded until the filter ruptures or the system pressure drop of 30 in. w.c. (7.5 kPa) is reached. The filter will also be weighed at 20 and 30 in. w.c. (5.0 and 7.5 kPa) if the filter has not yet ruptured at this pressure drop. Each test sequence is expected to last approximately three days.

Facility Representative Radial Flow HEPA Filter

Both of the radial flow HEPA filters will be tested: the facility representative radial filter for remote change housings and for safe change housings. The radial filter for remote change housings is illustrated in Figures 2A-B while the radial filter for safe change housings is illustrated in Figures 2C-D as originally designed using gel seals. The two filters differ in their installation sealing and also slightly in the pleat spacing and the ID and OD of the two filters. For the purposes of the ICET tests, the filters will be modified to include a gasket seal rather than the customary gel seal. The housing utilized will likewise be modified to accommodate this change including the addition of a locking mechanism to hold the filters in place. As the remote change HEPA filter has slightly less media area and greater pleat count it is anticipated that it

will have a higher pressure drop at the same particle loading compared to the safe change HEPA. Figures 2A-B show the gel seal is on the underside of the inlet flange. This type of filter is installed vertically at the facility using remote cranes and the filter sealed in the gel seal using gravity.

Figures 2C-D show the radial flow HEPA filter that is used in the safe change housings. This filter has the gel seal in an annular groove on the inlet flange and is placed in a safe change housing in a horizontal configuration. A special support consisting of a series of guiding bars is needed to allow the filter to be pushed into the gel seal.

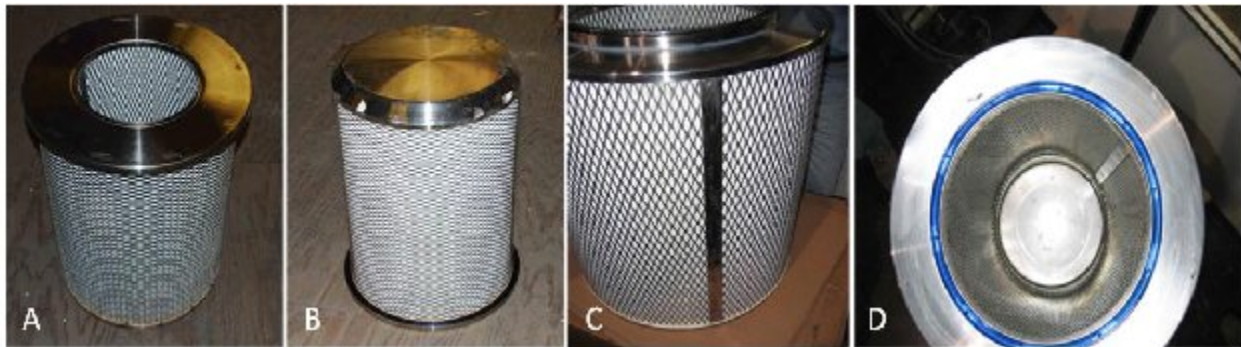

Figure 2. A: Radial flow HEPA filter to be used in the facility's remote change housing. B: Gel seal shown on the bottom side of inlet flange of the facility's remote change HEPA filter. C: Side view of the facility's safe change radial flow HEPA filter. D: Gel seal in inlet annular groove of the facility's safe change radial flow HEPA filter.

The test housing is designed to hold two radial flow HEPA filters, but only one will be tested at a time. The filter slot farthest from the housing dead end will be used for both the safe change and the remote change HEPA filter allowing direct comparisons can be made without introducing particle loading differences due to the distance from the dead end of the housing.

Flanders designed the filter housing to accommodate either one safe change or one remote change filter both of which are modified to accommodate gasket seals. The remote change filter also has a slightly modified end caps. The gasket design modifications will not affect the filter pack design and thus will not affect loading performance for the final facility HEPA filters. For the proposed DOE facility tests, only one remote change filter will be tested at a time in the filter housing to avoid uncertainties in velocity and test dust uniformity. For the planned particle loading tests, the gasket seal filters and clamping mechanism will be used so that the filter can be periodically removed from the housing and weighed. The gasket seal filters are used rather than the gel seal in the facility's HEPA filters because loss of gel seal during filter removal will interfere with the filter weighing. After the housing, test ducts, blower, aerosol generators and test equipment are installed, the air flow uniformity and particle concentration uniformity will be determined. The housing and ducts will be leaked tested using the procedures in Section TA of ASME AG-1.[15] The traditional filter leak test in Section TA of ASME AG-1 to measure the filter seal to the housing is not needed because more accurate efficiency tests are conducted. Preliminary tests will be conducted to determine the effect of particle loss in the duct between the size distribution measurement and the HEPA filter on the size distribution at the filter.

As stated earlier, the filters are modified to allow both the safe change and remote change HEPA filters to be tested in the same housing. The same housing slot will be used for both the safe change and the remote change filters to maintain the same particle loading in the test system. The “dead end” effects in the housing will be constant for both filter designs. Figure 3 illustrates the air flow through single radial flow HEPA filter in the filter housing designed for ICET.

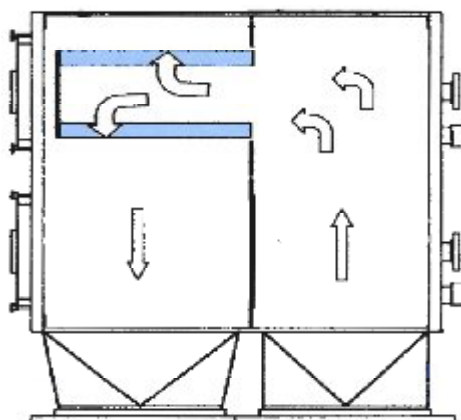

Figure 3. Schematic of air flowing through single radial flow HEPA filter in the filter housing designed for ICET. The housing will allow both the safe change and remote change filter designs to be used.

The difference in the design and construction of the safe change and remote change HEPA filters is expected to result in different particle loading. Since the pleat spacing is somewhat tighter for the filter used in the remote housing, it should have a lower particle loading capacity than the filter used in the safe-change housing. The specific details of the filter designs are given in Table 2.

Table 2. Comparison of parameters for radial HEPA filters used in remote and safe change filter housing.

Parameter	Remote	Safe Change
Inside Diameter of media pack	12.625 in. (30.068 cm)	13.625 in. (34.608 cm)
Pack Depth	3.0 in. (7.6 cm)	3.0 in. (7.6 cm)
Minimum Effective filter media area	307.7 ft ² (28.59 m ²)	307.7 ft ² (28.59 m ²)
Design Effective filter media area	314 ft ² (29.2 m ²)	320 ft ² (29.7 m ²)
Pack media width	22.84 in. (58.01 cm)	22.25 in. (56.52 cm)
Pleats per inch at inlet face	8.3 pleats/in. (3.3 pleats/cm)	8.1 pleats/ in. (3.2 pleats/cm)
dP at 1000 cfm (28.32 m ³ /min)	1.55 in. (3.94 cm)	1.30 in. (3.30 cm)
Mass of filter (to be confirmed for each filter)	62 lbs (28 kg)	49 lbs (22 kg)

The major difference in the two filter designs is the increased pleat packing density for the remote filter applications. The 8.3 pleats/in. (3.3 pleats/cm) and the nozzle configuration of the remote change filter result in a higher initial pressure drop (1.55 in. w.c. (386 Pa)) compared to the 8.1 pleats/in. (3.2 pleats/cm) and 1.30 in. w.c. (324 Pa) for the safe change filter applications.

Filter Wet Overpressure Tests

Flanders will conduct wet overpressure tests on four new filters per ASME AG-1 code to provide confidence that the filters will pass the qualification tests. These tests will be completed prior to the tests indicated in Table 1. The wet overpressure tests will be monitored as part of this project. These tests are important to confirm that the filters will not suffer structural damage at 10 in. w.c. (2.5 kPa) dP under humid conditions.

AEROSOL GENERATION

Carbon black

The first step in the aerosol generation process is the ability to reliably control and vary the particle size distribution of the challenge aerosol. Because of its similarity to dry smoke, carbon black has been chosen as one of three challenge aerosols for evaluating the performance of the facility representative radial flow HEPA filters. Loughborough at AEA Technology Harwell Laboratory in the UK conducted tests challenging radial flow filters with carbon black over two decades ago.[14] Loughborough utilized carbon black with a reported mass median diameter (MMD) of 600 nm dispensed by an ASHRAE dispenser (powder feeder) at a rate of 0.3 to 2.4 g/min. Carbon black products range in particle size from ~50 nm to ~250 nm. The specific product chosen is an N990 carbon black manufactured by CANCARB in Canada. The reported particle size for the CANCARB product is ~250 nm. The following values or ranges with respect to the particle size distribution (PSD) of the carbon black aerosol will be:

1. GMD: 250 to 800 nm (MMD 1 – 5 μm)
2. GSD: ≤ 2.2
3. Number density (#/cc): 10^5 to 10^6

A problem with the carbon black aerosols that will have to be controlled and measured is the tendency to form agglomerates as illustrated in Figure 4.

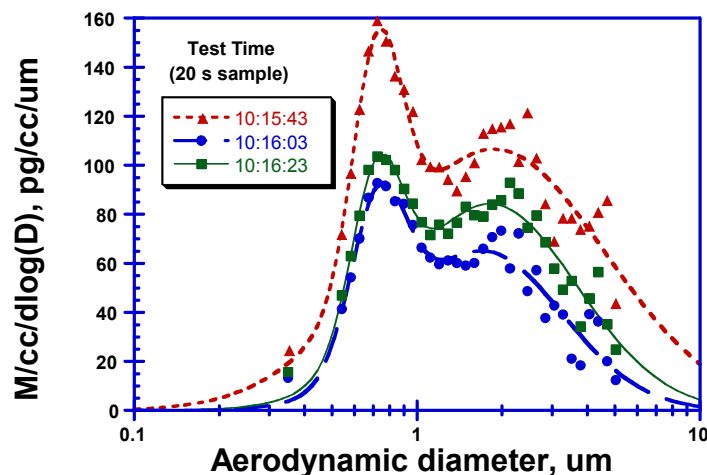

Figure 4. Size distribution of carbon black measured with APS at different times showing the primary size of 0.7 μm and a secondary size of 2.0 μm due to agglomeration of the primary particles.

Alumina

Alumina, $\text{Al}(\text{OH})_3$, will be used as a second test aerosol to provide filter loading data for small particle sizes. Alumina has been used successfully in filter loading tests [9,10]. The MMD of alumina particles is 0.3 μm .

Arizona Test Dust

Appropriately sized Arizona Road Dust (ISO 12103-1 A1 Ultrafine or A2 Fine Test Dust from Powder Technology Inc.) will be used as the third challenge aerosol.

DATA COLLECTION

Filter Data

For each filter received for testing, the following information will be recorded. The filter will be weighed prior to first use and after one hour of pre-conditioning to clean ambient air with the filter installed in the housing and operated at the rated flow rate. Filters will be weighed using a Mettler Toledo Model SB32001 top-loading balance.

1. Identification (serial) number
2. Filter manufacturer
3. DOP Filtering Efficiency (FE) (determined by manufacturer and FTF)
4. Filter dimensions (pleat depth, width, ID and OD, pleats/cm)
5. Initial weight (g) prior to use
6. Filter weight (g) after operating in clean air for one hour.

Test Conditions for Dry (40-50% RH) Loading to 30 in.

Protocol for loading filters at 40-50% RH

- a. Filters will be inserted into the test stand and exposed to airflow for one hour without aerosols being injected into the test stand, removed, and weighed to establish the tare weight of the filter. Once the tare weight is determined, the filter will be placed back into the test stand and challenge with aerosol will begin.
- b. A gravimetric determination of the mass of aerosol captured versus filter dP will be made in order to generate loading curve. The filter mass measurements will be supplemented with upstream mass concentration measurements. Each filter will be loaded with the appropriate aerosol challenge and removed for weighing at regular intervals. Filter mass will be determined at 4.0, 7.0, and 10 in. w.c. (1.0, 1.7, and 2.5 kPa). Additional data will be collected at 20 and 30 in. w.c. (5.0 and 7.5 kPa) or until downstream measurements indicate the loss of integrity of the filter.

Note that the filter is weighed with no drying so that any moisture on the filter is included in the mass. If the RH in the test duct is the same as ambient and during the filter weighings, one can

then assume equilibrium moisture on the filter media and on the test particles. This will provide the most accurate relationship between particle mass accumulation on the filter and the filter pressure drop. Since changes in the RH can affect the particle deposit morphology and hence the filter dP, it is desirable to maintain a constant RH as much as possible. Since the three test aerosols are relatively non hygroscopic, the effect of adsorbed moisture should be minimal.

The following information will be recorded for each filter tested. The initial dP of each filter will be recorded and the initial filtering efficiency (FE) will be determined. At the completion of each test segment, the weight of the filter tested will be recorded.

1. Initial Efficiency (Carbon Black, Arizona Test Dust, or Alumina)
 - a. Particle number and mass size distribution upstream of filter (PSD_{up})
 - b. Number density upstream (N_{up})
 - c. Particle number and mass size distribution downstream of filter (PSD_{dn})
 - d. Number density downstream (N_{dn})
 - e. Feeder conditions (g/min)

2. Particle Loading (Carbon Black, Arizona Test Dust, or Alumina)
 - a. Particle number and mass size distribution upstream of filter (PSD_{up})
 - b. Number density upstream (N_{up})
 - c. Particle number size distribution downstream of filter (PSD_{dn})
 - d. Feeder conditions (g/min)
 - e. Photometer downstream (periodically upstream for calibration). The downstream photometer is used to monitor the filter efficiency in case of media tears or filter rupture.
 - f. Pilot cascade impactor periodically for mass size distribution

3. Test Stand Conditions vs Time (t), continuous
 - a. Volumetric flow (Q)
 - b. Temperature (T)
 - c. Relative Humidity (RH)
 - d. Differential temperature across filter (dT)
 - e. Differential pressure across filter (dP)

4. Interruption of Particle loading for filter weights and photos
 - a. The loading test is stopped when the differential pressure reaches 4.0, 7.0, 10, 20 and 30 in. w.c. (1.0, 1.7, 2.5, 5.0, and 7.5 kPa)
 - b. The filter is quickly removed from the housing and weighed.
 - c. Photographs of the particle deposits on the filter are taken
 - d. The filter is replaced in the housing and the test continued.

Structural Failure Tests Under Particle Loading at High Temperature (165-170⁰F (73.9-76.7 ⁰C)) and Moisture (95-100% RH) Conditions

A test protocol will be developed that includes particle loading, moist conditions and high temperature. This test is designed to simulate accident conditions described where the HEPA

filter is challenged with aerosols under high moisture (95-100% RH) and high temperature conditions (165-170°F (73.9-76.7 °C)). The test consists of loading the HEPA filter to the normal change condition of 4.0 in. w.c. (1.0 kPa) of dP under ambient humidity conditions (40-50% RH). The same protocol for loading at 40-50% RH in the previous section is used here for particle loading to 4 in. w.c. (1.0 kPa).

The filter is then subjected to a simulated accident condition. Wet air at 95-100% RH and 165-170°F (73.9-76.7 °C) is added to the filter to simulate moisture and temperature from a steam leak. The added moisture will cause the filter dP to increase. If the filter does not rupture or the dP reaches a plateau, then particle loading is continued under the moist conditions. Particle loading is continued under the moist conditions until the filter ruptures or is blinded. The dP at rupture is recorded. Since the initial structural failure is typically pleat rupture, a photometer is used to monitor the increase in filter penetration.

Protocol for loading filters at 95-100% RH

- a. After the filter has been loaded to a differential pressure of 4 inches w.g., weighed and placed back in the test housing, the RH in the test stand will be increased to 95-100%, the temperature in the test stand will be increased to 165-170°F (73.9-76.7 °C), and the differential pressure across the filter will be continuously measured. This will result in a rapid increase in differential pressure. If the filter pressure drop continually increases, the wet filter will be removed from the housing and weighed at 10 in. w.c. (2.5 kPa). The filter is then inserted in the housing and the moisture and high temperature exposure continued. If no plateau in dP is reached, the wet filter is weighed again at 15, 20, and 30 in. w.c. (3.7, 5.0, and 7.5 kPa) or until rupture occurs.
- b. If the differential pressure across the test filter plateaus (little or no increase in dP is observed for a 15 minute period), the addition of aerosol challenge will be reinitiated under the elevated RH and temperature conditions. The filter will be weighed at 10, 15, 20 and 30 in. w.c. (2.5, 3.7, 5.0, and 7.5 kPa) if no rupture occurs. Photos of the filter are quickly taken of the wet filter.
- c. The filter will continue to be challenged with the combination of the appropriate aerosol and high RH (95-100%) until physical failure or the test stand maximum dP is reached.
- d. The determination of filter rupture is made using the photometer downstream of the filter. Since both water droplets and particles will produce photometer readings, a series of calibration curves are required under high temperature and moist conditions and under particle and high temperature and moist conditions.

RESEARCH PROJECT TEAM

The Institute for Clean Energy Technology (ICET) at Mississippi State University (MSU) was established in 1979 to support the Department of Energy's (DOE) Magnetohydrodynamic (MHD) power program. From its inception, its mission has been the development of advanced instrumentation and use of that instrumentation to characterize processes and equipment. ICET's testing capability, and its ability to rapidly deploy very sophisticated instrumentation in the field, has been an important component of its success.

ICET has a multidisciplinary staff of 30 FTE's, a blend of chemists, physicists, computer scientists, and chemical, electrical, and mechanical engineers. ICET scientists have leading-edge expertise in the application of lasers to energy and environmental cleanup. ICET's staff is a unique blend of measurement specialists, control specialists, and an experienced engineering and operations staff, primed to carry out its mission. ICET also employs students, both graduate and undergraduate, who further support research operations. ICET staff also includes a Certified Industrial Hygienist (CIH) and a Certified Hazardous Materials Manager (CHMM). These individuals ensure all activities conducted by ICET adhere to applicable environmental, safety and health practices.

To assist ICET research staff with project development and implementation, a Technical Working Group (TWG) has been established. This TWG is comprised of individuals representing DOE including Headquarters, Hanford ORP, Hanford RL, NNSA, ATI Filter Test Facility, and DOE contractors.

RESEARCH OVERSIGHT AND REVIEW

Due to critical need for data to be derived from the this research effort, the project will be subject to applicable DOE Quality Assurance requirements as well as final review by industry and academia.

To ensure the research is compliant with DOE quality assurance requirements, the research test plan has been developed in compliance with ASME NQA-1-2008, Quality Assurance Requirements for Nuclear Facility Applications as well ANSI/ASQ Z1.13-199, Quality Guidelines for Research.[16, 17] An ANSI Z1.13 Quality Assurance Plan has been developed to accompany the research test plan. All research activities are subject to audit by DOE.

A peer review panel comprised of industrial and academic experts in aerosol technology and filtration has been established to provide and final review of research results.

ACKNOWLEDGMENT

We acknowledge the support of this work under DOE Cooperative Agreement DE-FC01-06EW07040.

REFERENCES

[1] "HEPA Filters Used in the Department of Energy's Hazardous Facilities"; Defense Nuclear Facilities Safety Board; DNFSB/TECH-23, May (1999).

[2] http://www.dnfsb.gov/pub_docs/recommendations/all/rec_2000_02.pdf

[3] "A Report and Action Plan in Response to Defense Nuclear Facilities Safety Board Technical Report 23," Department of Energy (DOE), December (1999).

WM2010 Conference, March 7-11, 2010 Phoenix, AZ

- [4] S.L. ALDERMAN et al, "High Efficiency Particulate Air Filter Test Stand and Aerosol General for Particle Loading Studies", Rev. Sci. Instrum. 78, 085-105 (2007).
- [5] ARUN KUMAR et al, "Evaluation of Mass Emission Rates Down Stream of HEPA Filters as a Function of Source Terms and Selected Failure Modes", Waste Management '04 Conference, Tucson, AZ, February 29-March 4 (2004).
- [6] ARUN KUMAR et al, "Evaluation of Emissions from HEPA Filters as a Function of Challenge Conditions", IT3 '04 Conference, Phoenix, AZ, May 10-14 (2004).
- [7] S.L. ALDERMAN et al, "The Effects of Media Velocity and Particle Size Distribution on Most Penetrating Particle Size and Filter Loading Capacity of 12"x12"x11.5" AG-1 HEPA Filters", Nuclear Air Cleaning Conference, (2008).
- [8] S.L. ALDERMAN et al, "Evaluation of the Effect of Media Velocity on Filter Efficiency and Most Penetrating Particle Size of Nuclear Grade High-Efficiency Particulate Air Filters", Journal of Occupational and Environmental Hygiene, 5:11,713-720 (2008).
- [9] DOE-STD-1066-99, DOE Standard, Fire Protection Design Criteria, <http://www.hss.energy.gov/csa/csp/hepa/docs/std106699.pdf> (1999)
- [10] Bergman W. et al, "Enhanced Filtration Program at LLL- A Progress Report" 17th DOE Nuclear Air Cleaning Conference, pp. 1058 – 1099 (1978).
- [11] Bergman, W. HEPA Filter Particle Loading, 29th DOE Nuclear Air Cleaning Conference, (2006).
- [12] Ballinger, N. Y., Peter C. Owczarski, K. Hashimoto, G. Nishio, S. Jordan, and W. Lindner, "Aerosols Released in Accidents in Reprocessing Plants", pp. 278-292, Nuclear Technology, vol. 81, May 1988.
- [13] Beyler, C. and N. Iqbal, "Smoke Aerosol Exposure to HEPA Filters," pp. 437-442, Proceedings of the International Conference on Fire Research and Engineering, September 10-15, 1995, Orlando, Fl.
- [14] D. Loughborough, "The Dust Holding Capacity of HEPA Filters", 21st DOE/NRC Nuclear Air Cleaning Conference
- [15] ASME AG-1-2009, Code on Nuclear Air and Gas Treatment, American Society of Mechanical Engineers, http://catalog.asme.org/Codes/PrintBook/AG1_2009_Code_Nuclear_Air_Gas.cfm (2009)
- [16] http://catalog.asme.org/Codes/PrintBook/NQA1_2008_Quality_Assurance.cfm
- [17] <http://webstore.ansi.org/RecordDetail.aspx?sku=ANSI%2fASQ+Z1.13-1999>